

TEST REPORT

ACCORDING TO:

EN 50131-3:2009
EN 50131-1:2006+A1:2009+A2:2017+A3:2020

FOR:
Paradox Security Systems Ltd.

EUT:
Control Panel

Model:
SP7000+

This report is in conformity with ISO/ IEC 17025. The "A2LA Accredited" symbol endorsement applies only to the tests and calibrations that are listed in the scope of Hermon Laboratories accreditation. The test results relate only to the items tested.
This test report shall not be reproduced in any form except in full with the written approval of Hermon Laboratories Ltd.

Table of contents

1	Applicant information.....	3
2	Equipment under test attributes	3
3	Manufacturer information	3
4	Test details.....	3
5	EUT description.....	4
5.1	General information.....	4
5.2	Setup and settings.....	7
6	Tests summary.....	8
7	Tests results.....	10
7.1	Reduced functional test procedure and results	17
7.2	Processing intruder alarm signals or messages test procedure and results.....	19
7.3	Processing of hold-up signals or messages test procedure and results.....	22
7.4	Processing of tamper signals or messages test procedure and results.....	24
7.5	Processing of fault signals or messages test procedure and results.....	27
7.6	Access level test procedure and results	30
7.7	PIN code test procedure and results	32
7.8	Invalid authorization attempts test procedure and results	34
7.9	Setting procedures test procedure and results.....	37
7.10	Prevention of setting and overriding of prevention of setting test procedure and results	40
7.11	Unsetting test procedure and results.....	43
7.12	Setting and/or unsetting automatically at pre-determined times test procedure and results	46
7.13	Availability of indications test procedure and results	48
7.14	Tamper protection test procedure and results.....	50
7.15	Tamper detection - Access to the inside of the housing procedure and results	51
7.16	Tamper detection - Removal from mounting test procedure and results	53
7.17	Testing of I&HAS timing performance test procedure and results.....	55
7.18	Monitoring of interconnections test procedure and results	56
7.19	Testing of monitoring of periodic communication test procedure and results	57
7.20	Testing of verification during setting procedure test procedure and results.....	58
7.21	Event log test procedure and results	59
7.22	Marking and documentation test procedure and results.....	62
8	APPENDIX A Test equipment and ancillaries used for tests.....	65
9	APPENDIX B Test laboratory description.....	66
10	APPENDIX C Abbreviations and acronyms	66
11	APPENDIX D Tests specifications	67
12	APPENDIX E Measurement uncertainties.....	67

1 Applicant information

Client name: Paradox Security Systems Ltd.
Address: 780 INDUSTRIAL BLVD ST-EUSTACHE, QC, CANADA J7R 5V3
Telephone: +1-450-491-7444
Fax: +1-450-497-1095
E-mail: alexc@paradox.com
Contact name: Mr. Alex Chaplik

2 Equipment under test attributes

Description	Model Name	HW Version	SW Version
Control Panel	SP7000+	750-7000-020	V1.00
The CP was tested using ancillary control equipment:			
Keypad	TM70	680-6006-991	V1.03
Wired PIR detector	NV5	500-4000-020	V3.00

Condition of the equipment Test samples
Receipt date 6-Jul-22

3 Manufacturer information

Client name: Paradox Security Systems Ltd.
Address: 780 INDUSTRIAL BLVD ST-EUSTACHE, QC, CANADA J7R 5V3
Telephone: +1-450-491-7444
Fax: +1-450-497-1095
E-mail: alexc@paradox.com
Contact name: Mr. Alex Chaplik

4 Test details

Project ID: 47274
Location: Hermon Laboratories Ltd.
Harakevet Industrial Zone, Binyamina 30500, Israel
Test started: 06-Jul-22
Test completed: 07-Aug-22
Test specification(s): EN 50131-3:2009, EN 50131-1:2006+A1:2009+A2:2017+A3:2020

5 EUT description

5.1 General information

The EUT is control panel, model SP7000+ which include wired interconnection alarms components. The control panel classified as Environmental **Class II**, Security **Grade 2**, fixed equipment, **Type A** Power Supply. The control panel is powered by 100-240VAC for EPS and include internal rechargeable battery 12Vdc, 7Ah.

The EUT is presented in Photographs 5.1.1 to 5.1.7

Photograph 5.1.1 - General view

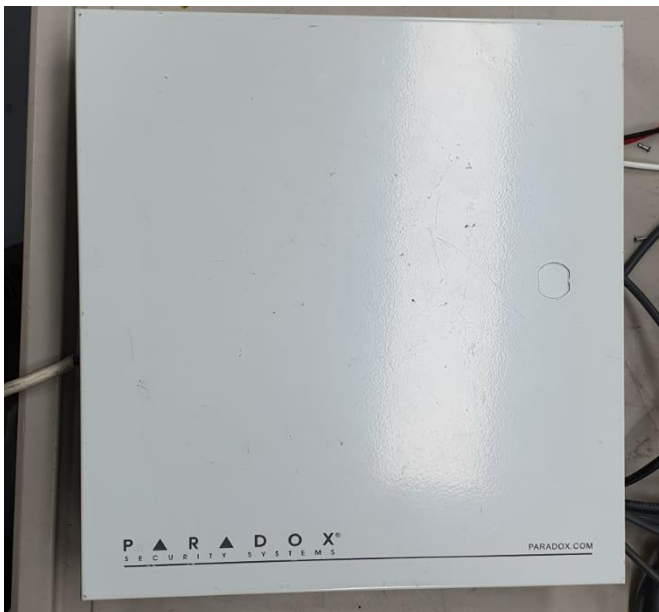

Photograph 5.1.2 -Rear view

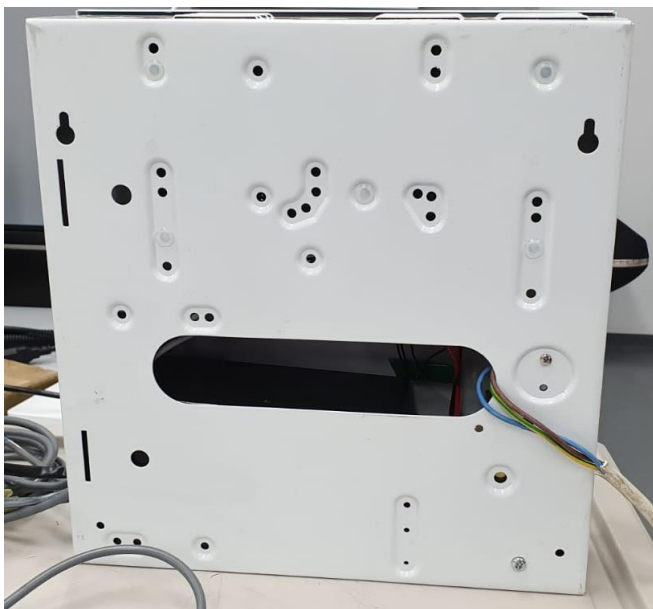

Photograph 5.1.3 - Internal view

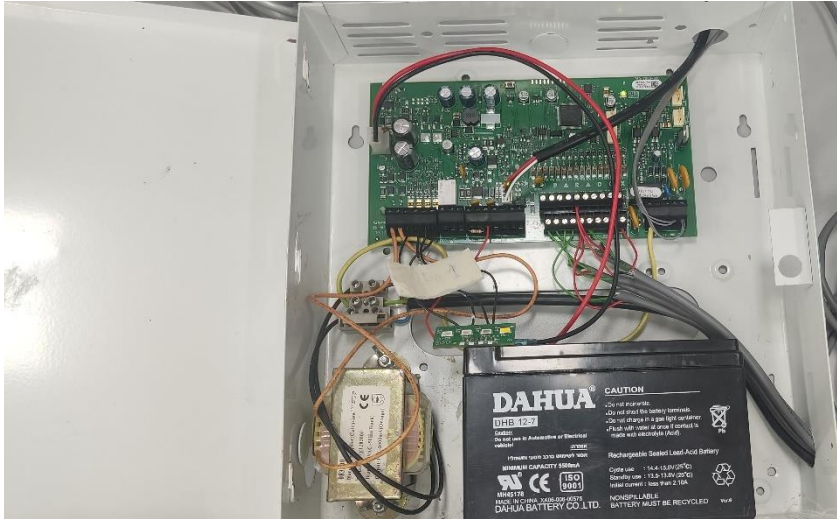

Photograph 5.1.4, 5.1.5 -PCB view

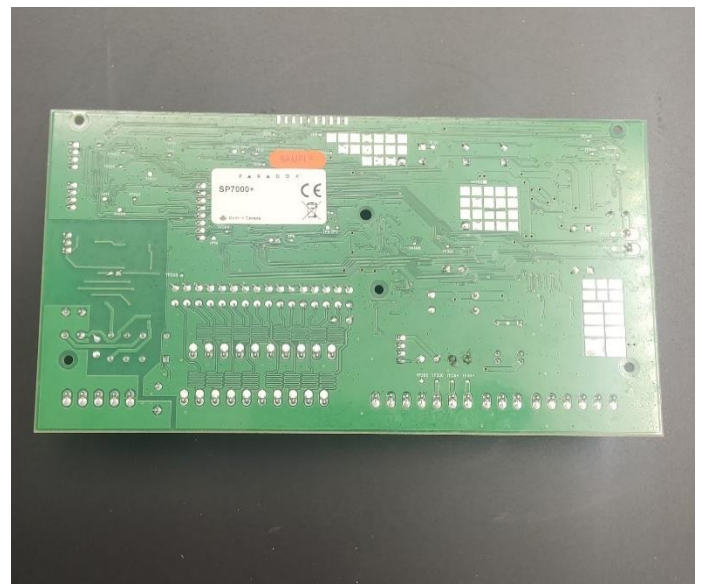
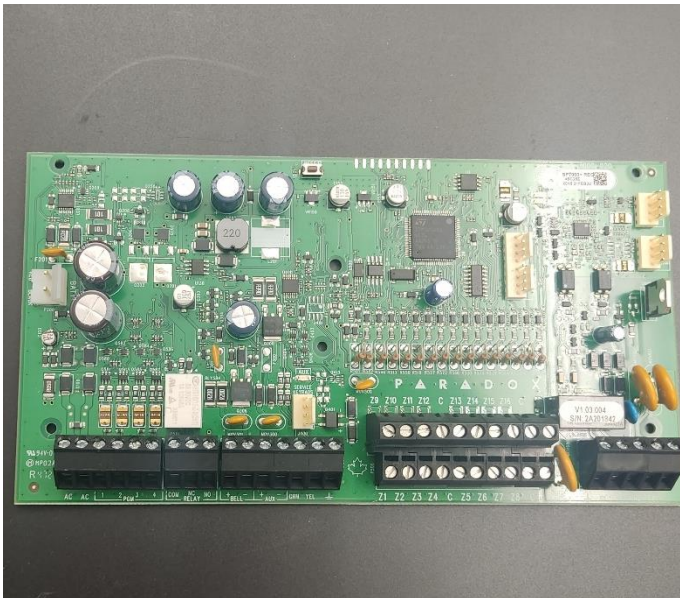

Photograph 5.1.6 – Rechargeable Battery



Photograph 5.1.7 – Product label

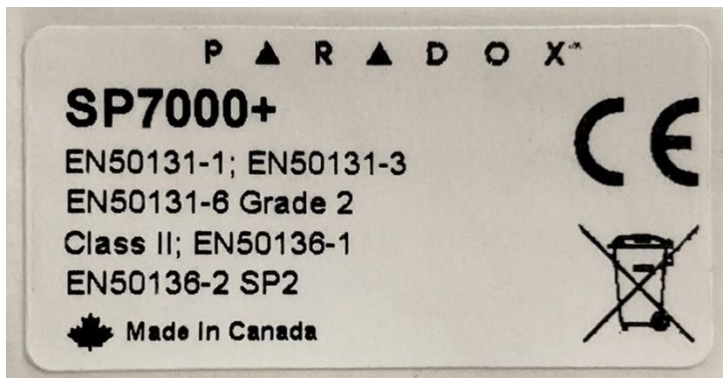

5.2 Setup and settings

Figure 5.2.1 Setup configuration

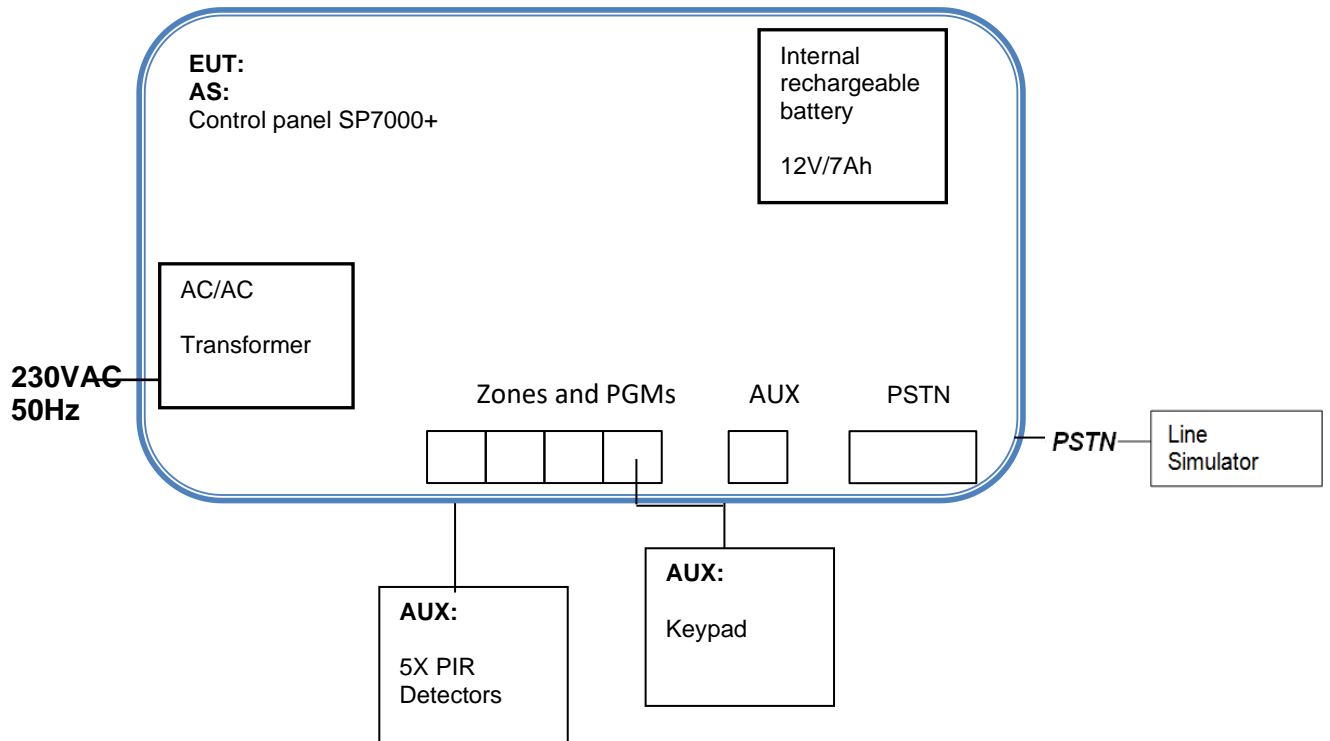

6 Tests summary



Test	Status
EN 50131-3	
Section 11.3, Reduced functional test	Pass
Section 11.4.1, Functional tests: Processing intruder alarm signals or messages	Pass
Section 11.4.2, Functional tests: Processing of hold-up signals or messages	Pass
Section 11.4.3, Functional tests: Processing of tamper signals or messages	Pass
Section 11.4.4, Functional tests: Processing of fault signals or messages	Pass
Section 11.4.5, Functional tests: Processing masking signals or messages	N/A*
Section 11.4.6, Functional tests: Processing reduction of range signals or messages	N/A*
Section 11.4.7, Functional tests: CIE Processing in the presence of non-I&HAS inputs	N/A
Section 11.5, Access level	Pass
Section 11.6.1, Authorization requirements: Mechanical key tests	N/A
Section 11.6.2.1, Authorization requirements: Logical key tests: Digital key tests	N/A
Section 11.6.2.2, Authorization requirements: Logical key tests: PIN code tests	Pass
Section 11.6.3, Authorization requirements: Invalid authorization attempts	Pass
Section 11.7.1, Operational tests: Setting procedures	Pass
Section 11.7.2, Operational tests: Prevention of setting and overriding of prevention of setting procedures	Pass
Section 11.7.4, Operational tests: Unsetting procedures	Pass
Section 11.7.5, Operational tests: Setting and/or unsetting automatically at pre- determined times	Pass
Section 11.7.6, Operational tests: Inhibit and isolate functions	N/A
Section 11.7.7, Operational tests: Test functions	Pass
Section 11.7.8, Operational tests: Other functions	N/A
Section 11.7.9, Operational tests: Monitoring of CIE processing	N/A*
Section 11.7.10, Operational tests: Availability of indications	Pass
Section 11.8.2, Tamper security tests: Tamper protection	Pass
Section 11.8.3, Tamper security tests: Tamper detection - Access to the inside of the housing	Pass
Section 11.8.4, Tamper security tests: Tamper detection - Removal from mounting	N/A**
Section 11.8.5, Tamper security tests: Tamper detection - Penetration of the housing	N/A*
Section 11.9, Substitution tests	N/A*
Section 11.10, Testing of I&HAS timing performance	Pass
Section 11.11.1, Testing for interconnections: Monitoring of interconnections	Pass
Section 11.11.2, Testing for interconnections: Testing of monitoring of periodic communication	Pass
Section 11.11.3, Testing for interconnections: Testing of verification during setting procedure	Pass
Section 11.12, Event log	Pass
Section 11.13, Marking and documentation	Pass
Section 11.14, Environmental and EMC tests	See Note1

* Not mandatory for Grade 2

** Not mandatory for wired CIE Grade 2

Note 1: See separate report: PARENV_EN.47274 and PAREMC_ 47274

The EUT was subjected to tests according to EN 50131-3:2009 in conjunction with EN 50131-1:2006+A1:2009 +A2:2017+A3:2020 standards for Security Grade 2, Environmental Class II equipment as listed in the table above and found to be in compliance with the standards requirements.

Revision History Table:					
Date	File No.	Prepared	Reviewed	Approved	Amendment Description
August 30, 2022	PARIAS_EN 50131-3. 47274	Mr. Golan Taib Test Engineer Product safety & Security Systems 	Mr. Ilan Benihass Team leader, Product Safety & Security Systems 	Mr. Michael Brun, Safety Group Manager 	Original Report

7 Tests results

Table 7.1 - EN 50131-3 Compliance General Matrix

The results apply to all EUTs below according to their technology type and security grade

Model	Applicable Standard	Security Grade
SP7000+	EN 50131-3	2

I. EN 50131-3 reference		Result				Remarks and/or document reference
Section	Requirement	C	NC	NA	NT	
4	Equipment attributes					
4.1	General	✓				
4.2	Functionality	✓				No additional function that affects EN compliance
5	CIE construction	✓				Single housing, fixed equipment
6	Security grade	✓				2
7	Environmental performance					
7.1	Requirements	✓				Class II
7.2	Environmental and EMC tests	✓				See 11.14 below
8	Functional requirements					
8.1	Inputs	✓				
8.1.1	Intruder detection	✓				Magnetic contact detector and wired PIR detectors
8.1.2	Hold-up device	✓				Panic Alarm code considered hold-up device
8.1.3	Tamper	✓				Tamper of all devices
8.1.4	Fault	✓				Checked
8.1.5	User input	✓				From Keypad
8.1.6	Masking			✓		Not applicable for Grade 2
8.1.7	Movement detector range reduction			✓		Not applicable for Grade 2
8.1.8	Non-I&HAS inputs			✓		Not applicable for Grade 2
8.2	Outputs	✓				Installation documentation identifies which configurations are available
8.3	Operation	✓				Provided by correlate Keypad. Access restricted by PIN code.
8.3.1	Access levels	✓				Access restricted according to EN 50131-1:2006, 8.3.1. Installer access (level 3) is permitted with user (level 2) authorization only.
8.3.2	Authorization	✓				Access to the functions of CIE is restricted as required by EN 50131-1
8.3.2.1	Use of a mechanical key			✓		No mechanical keys are used
8.3.2.2	Use of logical keys	✓				Logical keys are used by PIN codes
8.3.2.2.1	Use of PIN codes	✓				PIN code by keypad buttons
8.3.2.2.2	Digital keys			✓		No digital keys
8.3.2.2.3	Biometric keys			✓		Biometric keys not used

I. EN 50131-3 reference		Result				Remarks and/or document reference
Section	Requirement	C	NC	NA	NT	
8.3.2.3	Use of methods of authorization in combination			✓		Two or more methods not used together to give authorization
8.3.2.4	Detection of repeated invalid authorization attempts	✓				After 5 invalid code entries, special tamper message was displayed on the user interface screen.
8.3.3	Setting procedures	✓				Setting from keypad. Keypad provides means to set automatically at pre-determined times. Keypad generates setting indication at pre-determined periods.
8.3.3.1	Prevention of setting and overriding of prevention of setting	✓				For all conditions of EN 50131-1:2006, 8.3.5, the set Keypad is prevented.
8.3.3.2	Exit route facility	✓				Provided CIE provides means to indicate that the exit procedure has commenced by BEEP sound and time indication.
8.3.3.3	Failure to set	✓				"Fail to set" indication and notification
8.3.3.4	Set state	✓				Set indication provided by Keypad. Opening the door to the entry/exit route shall initiate an entry procedure
8.3.4	Unsetting procedure	✓				The unit is able to unset.
8.3.5	Restore function	✓				Provided
8.3.6	Inhibit function			✓		No Inhibit function
8.3.6.1	Automatic inhibit function	✓				Automatic bypass
8.3.7	Isolate operation			✓		No option to isolate operation
8.3.8	Verification of I&HAS functions	✓				Periodic test by access level 2
8.3.9	Alarm point soak test mode			✓		No soak test option
8.3.10	Other functions	✓				All functions described in documentation
8.4	Processing	✓				Control Panel
8.4.1	Processing of input signals or messages	✓				As above
8.4.1.1	Alarm inputs	✓				a)
8.4.1.2	Priorities	✓				All processed and notified
8.4.2	Processing of user inputs	✓				The keypad are used by access level 2 therefore authorized as per 8.3.2
8.4.3	Monitoring of CIE processing			✓		Optional for security Grade 2
8.5	Indication					
8.5.1	General	✓				Provided at Keypad interface
8.5.1.1	Alarm, tamper and fault indications	✓				Acknowledgment by consulting the event log by the user with appropriate access level.
8.5.1.2	Other conditions			✓		No such conditions
8.5.2	Visual Indicators			✓		Different Icons and marks at the keypad
8.5.3	Priority of indications			✓		No share of indications
8.6	Notification outputs	✓				CP, Grade 2, Option C at: EN 50131-1:2006, 8.6, Table 10
8.6.1	Other notification			✓		Not applicable for the specific products under test
8.7	Tamper security (detection/protection)	✓				See below
8.7.1	Tamper protection	✓				1J impacts for Grade 2 as part of ENV tests See 11.8.2 below

I. EN 50131-3 reference		Result				Remarks and/or document reference
Section	Requirement	C	NC	NA	NT	
8.7.2	Tamper detection	✓				Tested
8.7.2.1	Access to the inside of housing	✓				See 11.8.3 below
8.7.2.2	Removal from mounting			✓		Not mandatory to wired Grade 2 CIE
8.7.2.3	Penetration of the housing			✓		Not mandatory for Grade 2
8.7.3	Monitoring of substitution			✓		Not mandatory for Grade 2
8.8	Interconnections	✓				120 min intervals communication check for Grade 2
8.9	Timing	✓				Intruder, hold-up, and tamper signals with an active period exceeding 400ms processed
8.10	Event Recording	✓				Events logged in event log buffer where they can be consulted by appropriate Access Level, also stored in ARC (Monitoring station).
8.10.1	Event recording at the CIE	✓				Tested on CP. All events properly logged in memory.
8.10.2	Event recording at the ARC or other remote location	✓				Negative acknowledgement provided when transmission of events not successful.
8.11	Power Supply	✓				See separate HL test report for EN 50131-6: PARIAS_EN 50131-6.47274
9	Product documentation					
9.1	Installation and maintenance	✓				See 11.13 below
9.2	Operating Instructions	✓				See 11.13 below
10	Marking and labeling	✓				See 11.13 below
11	Tests					
11.1	Test Conditions					Temperature: 15-35°C Relative humidity: 25-75% Air pressure: 86-106kPa
11.2	Test procedures	✓				
11.3	Reduced Functional Test	✓				See Chapter 7.1
11.4	Functional tests					
11.4.1	Processing intruder alarm signals or messages	✓				See Chapter 7.2
11.4.2	Processing of hold-up signals or messages	✓				See Chapter 7.3
11.4.3	Processing of tamper signals or messages	✓				See Chapter 7.4
11.4.4	Processing of fault signals or messages	✓				See Chapter 7.5
11.4.5	Processing masking signals or messages			✓		Not mandatory for security Grade 2.
11.4.6	Processing reduction of range signals or messages			✓		Not mandatory for security Grade 2.
11.4.7	CIE Processing in the presence of non-I&HAS inputs			✓		No non-I&HAS inputs. Not applicable for the specific products under test
11.5	Access level					

I. EN 50131-3 reference		Result				Remarks and/or document reference
Section	Requirement	C	NC	NA	NT	
11.5.1	Access to the functions and controls	✓				See Chapter 7.6
11.6	Authorization requirements					
11.6.1	Mechanical key tests			✓		No mechanical keys
11.6.2	Logical key tests					
11.6.2.1	Digital key tests			✓		No digital keys
11.6.2.2	PIN code tests	✓				See Chapter 7.7
11.6.2.3	Tests for authorization by biometric means			✓		Biometric means not used
11.6.2.4	Tests for authorization by combinations of keys			✓		No combinations used
11.6.3	Invalid authorization attempts	✓				See Chapter 7.8
11.7	Operational tests					
11.7.1	Setting procedures	✓				See Chapter 7.9
11.7.2	Prevention of setting and overriding of prevention of setting procedures	✓				See Chapter 7.10
11.7.3	The set state	✓				EN 50131-1, 8.3.7, options b and c for Grade 2 are provided
11.7.4	Unsetting procedures	✓				See Chapter 7.11
11.7.5	Setting and/or unsetting automatically at pre-determined times	✓				See Chapter 7.12
11.7.6	Inhibit and isolate functions			✓		No isolate operation
11.7.7	Test functions			✓		No special function
11.7.8	Other functions			✓		No mandatory functions found affected
11.7.9	Monitoring of CIE processing			✓		Optional for security Grade 2
11.7.10	Availability of Indications	✓				See Chapter 7.13
11.8	Tamper security tests					
11.8.1	ACE Type A			✓		No claim or reason for a type A classification
11.8.2	Tamper protection	✓				See Chapter 7.14
11.8.3	Tamper detection - Access to the inside of the housing	✓				See Chapter 7.15
11.8.4	Tamper detection - Removal from mounting			✓		Not mandatory to wired Grade 2 CIE
11.8.5	Tamper detection - Penetration of the housing			✓		Optional for security Grade 2
11.9	Substitution tests					
11.9.1	Tests for monitoring of substitution of components			✓		Optional for security Grade 2
11.9.2	Tests for monitoring of substitution – Timing requirements			✓		As above
11.10	Testing of I&HAS timing performance	✓				See Chapter 7.17
11.11	Testing for interconnections					
11.11.1	Monitoring of interconnections	✓				See Chapter 7.18

I. EN 50131-3 reference		Result				Remarks and/or document reference
Section	Requirement	C	NC	NA	NT	
11.11.2	Testing of monitoring of periodic communication	✓				See Chapter 7.19
11.11.3	Testing of verification during setting procedure	✓				See Chapter 7.20
11.11.4	Test for security of communication			✓		Optional for security Grade 2
11.12	Event log	✓				See Chapter 7.21
11.13	Marking and documentation	✓				See Chapter 7.22
11.14	Environmental tests operational					
	Dry Heat	✓				Separate HL TR PARENV_EN.47274
	Cold	✓				
	Damp heat (steady state)			✓		
	Temperature change			✓		
	Damp Heat (cyclic)	✓				
	Water Ingress			✓		
	Impact	✓				
	Free Fall			✓		
	Mechanical Shock	✓				
	Vibration, sinusoidal	✓				
	EMC	✓				Separate HL TR: PAREMC_47274
	Environmental tests endurance					
	Dry Heat			✓		
	Damp heat (steady state)	✓				Separate HL TR PARENV_EN.47274
	Damp Heat (cyclic)			✓		
	SO ₂ Corrosion			✓		
	Salt mist, cyclic			✓		

C= conform; NC= not conform; NA = not applicable; NT = not tested

Table 7.2 - EN50131-1 Compliance General Matrix

II. EN 50131-1 reference		Result				Remarks and/or document reference
Section	Requirement	C	NC	NA	NT	
4	System functions	✓				Security Grade 2 , Environmental Class II
5	System components	✓				
6	Security grading	✓				
7	Environmental classification	✓				
8	Functional requirements					
8.1	Detection of intruders, triggering, tampering and the recognition of faults					
8.1.1	Intruder detection	✓				See Table 7.1 above EN 50131-3 Table
8.1.2	Hold-up device-triggering	✓				
8.1.3	Tamper Detection	✓				
8.1.4	Recognition of faults	✓				
8.2	Other functions					
8.2.1	Masking			✓		Optional for Grade 2. Option not present in the system features
8.2.2	Movement detector range reduction			✓		
8.3	Operation					
8.3.1	Access levels	✓				See Table 7.1 above EN 50131-3 Table
8.3.2	Authorization	✓				
8.3.3	Setting and Unsetting	✓				
8.3.4	Setting	✓				
8.3.5	Prevention of setting	✓				
8.3.6	Overriding prevention of setting	✓				
8.3.7	Set state	✓				
8.3.8	Unsetting	✓				
8.3.9	Restoring	✓				
8.3.10	Inhibit			✓		
8.3.11	Isolate			✓		
8.3.12	Test	✓				
8.3.13	Other Functions			✓		
8.4	Processing					
8.4.1	Intruder signals or messages	✓				See Table 7.1 above EN 50131-3 Table
8.4.2	Hold-up signals or messages	✓				
8.4.3	Tamper signals or messages	✓				
8.4.4	Fault signal or messages	✓				
8.4.5	Masking signals or messages			✓		Masking and range reduction signals not mandatory for Grade 2 and not presented as system features
8.4.6	Reduction of range signals or messages			✓		
8.5	Indications					
8.5.1	General	✓				See Table 7.1 above EN 50131-3 Table
8.5.2	Availability of indications	✓				

II. EN 50131-1 reference		Result				Remarks and/or document reference
Section	Requirement	C	NC	NA	NT	
8.5.3	Canceling indication	✓				
8.5.4	Indication-Intrusion detectors	✓				
8.6	Notification	✓				See Table 7.1 above EN 50131-3 Table
8.7	Tamper Security					
8.7.1	Tamper protection	✓				See Table 7.1 above EN 50131-3 Table
8.7.2	Tamper detection	✓				
8.7.3	Monitoring of substitution			✓		Monitoring of substitution not mandatory for Grade 2 and not presented as a system feature
8.7.4	Monitoring of substitution-timing requirements			✓		
8.8	Interconnections					
8.8.1	General	✓				See Table 7.1 above EN 50131-3 Table
8.8.2	Availability of interconnections	✓				
8.8.3	Monitoring of interconnections	✓				
8.8.4	Verification	✓				
8.8.5	Security of communication			✓		Security of communication is optional in security grade 2
8.8.6	Signals or messages to be generated	✓				Fault signal and message
8.9	I&HAS timing performance					
8.9.1	Intruder detection, tampering and recognition of faults	✓				See Table 7.1 above EN 50131-3 Table
8.9.2	Processing	✓				
8.10	Event Recording	✓				
9	Power Supply					
9.1	Types of power supply	✓				Type A for CP
9.2	Requirements	✓				SD provides power for minimum of 12 hours for Grade 2 CP. See separate HL test report for EN 50131-6: PARIAS_EN 50131-6.47274
10	Operational reliability					
10.1	I&HAS components	✓				Analysis
11	Functional reliability	✓				Analysis
12	Environmental requirements	✓				Separate HL TR PARENV_EN.47274
12.1	Electromagnetic compatibility	✓				Separate HL TR PAREMC_47474
13	Electrical safety	✓				Separate HL TR PARSAF__Delta.EN.45821
14	Documentation	✓				See Chapter 7.22
15	Marking / Identification	✓				
Annex B	Requirements applicable when an I&HAS is remotely accessed					
B.1	General			✓		No remote access from a non-certified I&HAS equipment
B.2	Requirements			✓		As above

C= conform; NC= not conform; NA = not applicable; NT = not tested



Test specification:		Reduced functional test	
Test procedure:		EN 50131-3 TEST METHOD: 11.3 Reduced functional test	
Test mode:		Compliance	
Test Date:		4/8/22	
Atmospheric conditions during the test:		Temperature: 24.2 °C	Air Pressure: 1004hPa
Remarks:		Verdict: PASS Relative Humidity: 52 %	

7.1 Reduced functional test procedure and results

7.1.1 Test purpose

This test was performed to demonstrate the ability of the EUT to operate under full load conditions before and after other tests.

7.1.2 Test procedure

7.1.2.1 Reduced functional test shall be carried out in accordance with Table 7.1.1

7.1.3 Test results

Table 7.1.1 Test results

Step	Test Condition	Action	Measurement	Pass criteria	Verdict
1	CIE unset Absence of "intruder, tamper, fault signals and messages" No indication active	Apply an intruder alarm signal or message for 401ms	Area open indication on the keypad	Indications shall be according to the grade (as shown in EN 50131-1:2006, Tables 8 and 9).	P
2	As above +: one intruder alarm input, not allocated as an "entry route"	Attempt to set the system	Setting prevented	The system should be prevented from setting.	P
3	As in 1 above	Set the system	System set. symbol that indicates that the system set (Keypad indication)	Indications shall be according to the grade (as shown in EN 50131-1:2006, Tables 8 and 9).	P
4	CIE set	Apply an alarm signal or message as specified in 8.9.	Alarm Notifications OK	At least one notification configuration required by EN 50131-1:2006, Table 10, according to the grade, shall be activated in accordance with EN 50131-1:2006, Table 7.	P
5	CIE in "set condition" and in "alarm" conditions	Manually unset the CIE	System unset. Correct notifications and event log.	CIE unset Indications shall be according to the grade (as shown in EN 50131-1:2006, Tables 8 and 9). WD outputs shall silence,	P



Test specification:		Reduced functional test	
Test procedure:		EN 50131-3 TEST METHOD: 11.3 Reduced functional test	
Test mode:	Compliance	Verdict:	PASS
Test Date:	4/8/22		
Atmospheric conditions during the test:	Temperature: 24.2 °C	Air Pressure: 1004hPa	Relative Humidity: 52 %
Remarks:			

				Other notification output signals or messages may remain active until restored. Correct time and events sequences recorded	
6	CIE in "unset condition"	Restore CIE	Acknowledgement of messages is required when unsetting system. Restore at access levels 2,3	In accordance with 8.3.5	P

7.1.4 Results

- (X) The above results comply with this section of the standard.
- (...) The above results do not comply with this section of the standard.

Reference numbers of test equipment used

HL 2772	HL 3460
---------	---------

Full description is given in Appendix A.



Test specification: Processing intruder alarm signals or messages test			
Test procedure: EN 50131-3 TEST METHOD: 11.4.1 Processing intruder alarm signals or messages			
Test mode: Compliance		Verdict: PASS	
Test Date: 4/8/22			
Atmospheric conditions during the test:	Temperature: 24.2 °C	Air Pressure: 1004hPa	Relative Humidity: 52 %
Remarks:			

7.2 Processing intruder alarm signals or messages test procedure and results

7.2.1 Test purpose

To demonstrate the ability of the CIE to comply with 8.1.1, 8.3.5, 8.4.1, 8.4.1.2, 8.5, 8.6, 8.9 and 8.10:

- 1) receive and process an intruder signal or message, within the processing timing requirements of this specification, when the CIE is in the set and the unset conditions;
- 2) provide indication(s) and notification(s);
- 3) correctly record the event(s) in the event log;
- 4) restore in accordance with 8.3.5.

7.2.2 Test procedure

7.2.2.1 Apply an intrusion signal/message as specified in 8.9 to an intruder input and Test results monitoring that the input has been processed within the required time period and that the correct indication and notification(s) occur.

7.2.2.2 The results were documented as presented in Table 7.2.1.

7.2.3 Test results

Table 7.2.1 Test results

Step	Test Condition	Action	Measurement	Pass criteria	Verdict
	GENERAL CONDITION The CIE is in the condition described in the steps below with all inputs and outputs in normal condition.		GENERAL MEASUREMENT Record the condition of the indications and notifications of the CIE and any associated user input devices (EXAMPLE: remote keypads). Time when signal/message applied Time when notification occurs Record the event log.	GENERAL CRITERIA Processing shall be in accordance with EN 50131-1:2006, Table 7 and 8.4.1. The indications and notifications shall be in accordance with EN 50131-1:2006, Tables 8, 9 and 10	P
1	CIE in "set mode"	Apply intruder signal/message for 401ms	- Alarm activated in less than 1s. - Siren was activated - Burglar alarm, indication on the keypad and "Zone in alarm" logged in event log - The event was notified to ARC	General criteria + As defined in EN 50131-1:2006, 8.9, notification shall occur within the time specified by EN 50131-1:2006, 8.9. The logging shall be in accordance with 8.10.	P



Test specification: Processing intruder alarm signals or messages test			
Test procedure: EN 50131-3 TEST METHOD: 11.4.1 Processing intruder alarm signals or messages			
Test mode: Compliance		Verdict: PASS	
Test Date: 4/8/22			
Atmospheric conditions during the test:	Temperature: 24.2 °C	Air Pressure: 1004hPa	Relative Humidity: 52 %
Remarks:			

2	CIE in "set mode" (with alarm condition)	Unset the CIE	<ul style="list-style-type: none"> - After the user is introducing the user code for disarming. - Siren stopped within 1 sec. - Event log recorded the system unsetting "Disarm" and alarmed zone canceled "Zone alarm restore" 	General criteria Indications shall comply with 8.5.	P
3	CIE in "unset mode"	Restore (EXAMPLE: by entering a correct PIN number into the keypad)	<ul style="list-style-type: none"> - The system restored indication icon on the keypad is green, indicates that system is ready. - Event log recorded the system restored "Zone alarm restore." Event ended. 	In accordance with 8.3.5	P
4	CIE in "set mode" NOTE To verify that multiple signals or messages applied at the same alarm point, are recorded in the event log the number of times specified in EN 50131-1:2006, 8.10.	Apply the same Intruder signal/message for 401ms once more than the maximum number of times specified in EN 50131-1:2006, 8.10. Afterwards repeat step 3.	<ul style="list-style-type: none"> Limited by programmable function to 6 events from the same source. -Event log stopped logging after 6 intrusions from the same source 	The number of intruder alarms from the same source shall comply with EN 50131-1:2006, 8.10.	P
5	CIE in "unset mode" NOTE To verify that intruder signals or messages are not recorded in the event log.	Apply the same Intruder signal/message for 401ms four times. Afterwards repeat step 3.	<ul style="list-style-type: none"> -No logging in event log nor in ARC of alarms when CIE is unset mode -The CIE indicate that arm is not possible when intruder signal is applied. 	General criteria	P
6	CIE in "set mode". NOTE To verify that if multiple signals or messages are applied, at least one is processed correctly.	Apply intruder signals or messages equivalent to 5 % of the maximum alarm point capacity of the CIE or 5 (whichever is the greater) within 1s.	<ul style="list-style-type: none"> - Intruder alarm from 5 detectors was applied. - All intruder zones processed and logged in ARC and CP. 	At least one intruder signal or message shall be processed in accordance with 8.4.1.2 and 8.9.	P
7	CIE in "set mode" (with more than one alarm condition)	Unset the CIE	<ul style="list-style-type: none"> - The CIE indicate that arm is not possible when intruder signal is applied. - Event logs recorded the system unsetting and alarmed zone. 	General criteria Indications shall comply with 8.5.1.1.	P



Test specification:		Processing intruder alarm signals or messages test	
Test procedure:		EN 50131-3 TEST METHOD: 11.4.1 Processing intruder alarm signals or messages	
Test mode:	Compliance	Verdict: PASS	
Test Date:	4/8/22		
Atmospheric conditions during the test:	Temperature: 24.2 °C	Air Pressure: 1004hPa	Relative Humidity: 52 %
Remarks:			

8	CIE in "unset mode"	Restore all the conditions.	-The system is restored by means of level 2 or 3 PIN codes	In accordance with 8.3.5	P
---	---------------------	-----------------------------	--	--------------------------	---

7.2.4 Results

- (X) The above results comply with this section of the standard.
- (...) The above results do not comply with this section of the standard.

Reference numbers of test equipment used

HL 2772	HL 3460
---------	---------

Full description is given in Appendix A.



Test specification:		Processing of hold-up signals or messages test	
Test procedure:		EN 50131-3 TEST METHOD: 11.4.2 Processing of hold-up signals or messages	
Test mode:	Compliance	Verdict:	PASS
Test Date:	4/8/22		
Atmospheric conditions during the test:	Temperature: 24.2 °C	Air Pressure: 1004 hPa	Relative Humidity: 52 %
Remarks:			

7.3 Processing of hold-up signals or messages test procedure and results

7.3.1 Test purpose

To demonstrate the ability of the CIE including Hold-Up function to comply with 8.1.2, 8.3.5, 8.4.1, 8.5, 8.6, 8.9, 8.10 and to:

- 1) receive and process a hold-up signal or message, within the processing timing requirements of this specification, when the CIE is in the set and the unset conditions;
- 2) provide indication(s) and notification(s);
- 3) correctly record the event(s) in the event log;
- 4) restore in accordance with 8.3.5.

7.3.2 Test procedure

7.3.2.1 Apply a hold-up signal as specified in 8.9 or a hold-up message compatible to the CIE to a hold-up input when the system is in a variety of conditions shown in Table 1.1.1 below. The system shall be monitored to ensure that the input has been processed within the required time period and that the correct indication(s), notification(s) and event recording occur.

7.3.2.2 The results were documented as presented in Table 7.3.1.

7.3.3 Test results

Table 7.3.1 Test results

Step	Test Condition	Action	Measurement	Pass criteria	Verdict
	GENERAL CONDITION The CIE is in the condition described in the steps below with all inputs and outputs in normal condition.		GENERAL MEASUREMENT Record the condition of the indications and notifications of the CIE and any associated user input devices (EXAMPLE: remote keypads). Time when signal/message applied. Time when notification occurs. Record the event log.	GENERAL CRITERIA Processing shall be in accordance with EN 50131-1:2006, Table 7 and 8.4.1. The indications and notifications shall be in accordance with EN 50131-1:2006, Tables 8, 9 and 10	P
1	CIE in "set mode"	Apply hold-up signal/message for 401ms	- Panic alarm activated in less than 1s. - "Medical" or "FIRE" logged in event log - The event was notified to ARC - When disarming with duress code Notification occurred	General criteria + As defined in EN 50131-1:2006, 8.9, notification shall occur within the time specified by EN 50131-1:2006, 8.9.	P



Test specification:		Processing of hold-up signals or messages test	
Test procedure:		EN 50131-3 TEST METHOD: 11.4.2 Processing of hold-up signals or messages	
Test mode:		Compliance	
Test Date:		4/8/22	
Atmospheric conditions during the test:		Temperature: 24.2 °C	Air Pressure: 1004 hPa
Remarks:		Verdict: PASS	
		Relative Humidity: 52 %	

				The logging shall be in accordance with 8.10.	
2	CIE in "set mode" (with alarm condition)	Unset the CIE	System unset	General criteria. Indications shall comply with 8.5.	P
3	CIE in "unset mode"	Restore	Restored	In accordance with 8.3.5	P
4	CIE in "set mode" NOTE To verify that multiple signals or messages applied at the same alarm point, are recorded in the event log the number of times specified in EN 50131-1:2006, 8.10.	Apply the same hold-up signal/message for 401ms once more than the maximum number of times specified in EN 50131-1:2006, 8.10. Afterwards repeat step 3.	- Panic is not treated as EN function.	The number of intruder alarms from the same source shall comply with EN 50131-1:2006, 8.10.	N/A
5	CIE in "unset mode" NOTE To verify that intruder signals or messages are not recorded in the event log.	Apply the same Hold-up signal/message for 401ms four times. Afterwards repeat step 3.	- Panic is not treated as EN function	General criteria	N/A
6	CIE in "set mode". NOTE To verify that if multiple signals or messages are applied, at least one is processed correctly.	Apply hold-up signals or messages equivalent to 5 % of the maximum alarm point capacity of the CIE or 5 (whichever is the greater) within 1s.	- No multiple hold up points	At least one hold-up signal or message shall be processed in accordance with 8.4.1.2 and 8.9.	N/A
7	CIE in "set mode" (with more than one alarm condition)	Unset the CIE	- Event logs recorded the system unsetting. - Indication comply	General criteria Indications shall comply with 8.5.1.1.	P
8	CIE in "unset mode"	Restore all the conditions.	- The system is restored by entering the correct user code	In accordance with 8.3.5	P

7.3.4 Results

(X) The above results comply with this section of the standard.

(...) The above results do not comply with this section of the standard.

Reference numbers of test equipment used

HL 2772	HL 3460
---------	---------

Full description is given in Appendix A.



Test specification: Processing of tamper signals or messages test			
Test procedure: EN 50131-3 TEST METHOD: 11.4.3 Processing of tamper signals or messages			
Test mode: Compliance		Verdict: PASS	
Test Date: 4/8/22			
Atmospheric conditions during the test:	Temperature: 24.2 °C	Air Pressure: 1004 hPa	Relative Humidity: 52 %
Remarks:			

7.4 Processing of tamper signals or messages test procedure and results

7.4.1 Test purpose

To demonstrate the ability of the CIE to comply with 8.1.3, 8.3.5, 8.4.1, 8.5, 8.6, 8.9, 8.10 and to:

- 1) receive and process a tamper signal or message, within the processing timing requirements of this specification, when the CIE is in the set and the unset conditions;
- 2) provide indication(s) and notification(s);
- 3) correctly record the event(s) in the event log;
- 4) restore in accordance with 8.3.5.

7.4.2 Test procedure

7.4.2.1 Apply a tamper signal as specified in 8.9 or a tamper message compatible to the CIE, to a tamper input when the system is in a variety of conditions shown in Table 1.1.1 below. The system shall be monitored to ensure that the input has been processed within the required time period and that the correct indication(s), notification(s) and event recording occur.

7.4.2.2 The results were documented as presented in Table 7.4.1.

7.4.3 Test results

Table 7.4.1 Test results

Step	Test Condition	Action	Measurement	Pass criteria	Verdict
	<p>GENERAL CONDITION</p> <p>The CIE is in the condition described in the steps below with all inputs and outputs in normal condition.</p> <p>When multiple methods to set and to unset the CIE are provided, then the test shall be carried out for each method.</p>		<p>GENERAL MEASUREMENT</p> <p>Record the condition of the indications and notifications of the CIE and any associated user input devices (EXAMPLE: remote keypads).</p> <p>Time when signal/message applied.</p> <p>Time when notification occurs.</p> <p>Record the event log.</p>	<p>GENERAL CRITERIA</p> <p>Processing shall be in accordance with EN 50131-1:2006, Table 7 and 8.4.1.</p> <p>The indications and notifications shall be in accordance with EN 50131-1:2006, Tables 8, 9 and 10</p>	P
1	CIE in "set mode"	Apply tamper signal/message for 401ms	<ul style="list-style-type: none"> - Zone tamper alarm activated in less than 1s. - Siren was activated - "Zone Tamper" logged in event log - The event was notified to ARC 	<p>General criteria +</p> <p>As defined in 8.9 notification shall occur within the time specified by EN 50131 1:2006, 8.9.</p> <p>The logging shall be in accordance with 8.10.</p>	P



Test specification: Processing of tamper signals or messages test			
Test procedure: EN 50131-3 TEST METHOD: 11.4.3 Processing of tamper signals or messages			
Test mode: Compliance		Verdict: PASS	
Test Date: 4/8/22			
Atmospheric conditions during the test:	Temperature: 24.2 °C	Air Pressure: 1004 hPa	Relative Humidity: 52 %
Remarks:			

2	CIE in "set mode" (with tamper alarm condition)	Unset the CIE	- After the user is introducing the user code for disarming. - Siren stopped within 1 sec. - Event log recorded the system unsetting "Zone Tamper restore"	General criteria. Indications shall comply with 8.5.	P
3	CIE in "unset mode"	Restore	- The system restored keypad indicates that the system is ready. - Event log recorded the system restored	In accordance with 8.3.5	P
4	CIE in "set mode" NOTE To verify that multiple tamper signals or messages from the same source are recorded in the event log the number of times specified in EN 50131-1:2006, 8.10.	Apply the same tamper signal/message for 401ms once more than the maximum number of times specified in EN 50131-1:2006, 8.10. Afterwards repeat step 3.	Limited by programmable function to 4 events from the same source. -Event log stopped logging after 4 tamper signals from the same source	The number of intruder alarms from the same source shall comply with EN 50131-1:2006, 8.10.	P
5	CIE in "unset mode"	Apply tamper signal/message for 401ms.	- "Zone Tamper" logged in event log. - The event was notified to ARC -The system indicates "Not Ready" by the keypad, when tamper signal is applied.	General criteria + As defined in 8.9 notification (grade dependent, see EN 50131-1:2006, Table 7) shall occur within the time specified by EN 50131-1:2006, 8.9. The logging shall be in accordance with 8.10.	P
6	CIE in "unset mode" NOTE To verify that multiple tamper signals or messages from the same source are recorded in the event log the number of times specified in EN 50131-1:2006, 8.10.	Apply the same tamper signal/message for 401ms once more than the maximum number of times specified in EN 50131-1:2006, 8.10. Afterwards repeat step 3.	Limited by programmable function to 6 events from the same source. -Event log stopped logging after 6 tamper signals from the same source	The number of intruder alarms from the same source shall comply with EN 50131-1:2006, 8.10.	P



Test specification:		Processing of tamper signals or messages test	
Test procedure:		EN 50131-3 TEST METHOD: 11.4.3 Processing of tamper signals or messages	
Test mode:		Compliance	
Test Date:		4/8/22	
Atmospheric conditions during the test:		Temperature: 24.2 °C	Air Pressure: 1004 hPa
Remarks:		Verdict: PASS Relative Humidity: 52 %	

7	CIE in "set mode". NOTE To verify that if multiple tamper signals or messages are applied, at least one is processed correctly.	Apply tamper signals or messages equivalent to 5 % of the maximum alarm point capacity of the CIE or 5 (whichever is the greater) within 1s.	Intruder alarm from 5 detectors was applied. All tamper zones processed and logged in ARC and CP.	At least one tamper signal or message shall be processed in accordance with 8.4.1.3 and 8.9.	P
8	CIE in "set mode" (with more than one tamper alarm condition)	Unset the CIE.	- The system indicates "Not Ready" by the keypad, when tamper signal is applied. - Event logs recorded the system unsetting and alarmed zone.	General criteria Indications shall comply with 8.5.1.1.	P
9	CIE in "unset mode"	Restore all the conditions.	-The system is restored by means of level 2 or 3 PIN codes	In accordance with 8.3.5	P

7.4.4 Results

(X) The above results comply with this section of the standard.

(...) The above results do not comply with this section of the standard.

Reference numbers of test equipment used

HL 2772	HL 3460
---------	---------

Full description is given in Appendix A.



Test specification:		Processing of fault signals or messages test	
Test procedure:		EN 50131-3 TEST METHOD: 11.4.4 Processing of fault signals or messages	
Test mode:	Compliance	Verdict:	PASS
Test Date:	4/8/22		
Atmospheric conditions during the test:	Temperature: 24.2 °C	Air Pressure: 10004 hPa	Relative Humidity: 52 %
Remarks:			

7.5 Processing of fault signals or messages test procedure and results

7.5.1 Test purpose

To demonstrate the ability of the CIE to comply with 8.1.4, 8.3.5, 8.4.1, 8.5, 8.6, 8.9 and 8.10 to receive, process, log and notify a fault signal or message, within the requirements of this specification.

7.5.2 Test procedure

7.5.2.1 The tests shall be performed with the CIE in set and unset modes to ensure that detection of faults satisfies all relevant requirements.

7.5.2.2 Apply fault conditions as specified in 8.1.4, as shown in Table 7.5.1.

7.5.3 Test results

Table 7.5.1 Test results

Step	Test Condition	Action	Measurement	Pass criteria	Verdict
	GENERAL CONDITION The CIE is in the condition described in the steps below with all inputs and outputs in normal condition.	An EPS fault signal or message should be applied only where specifically stated.	GENERAL MEASUREMENT Record the condition of the indications and notifications of the CIE and any associated user input devices (EXAMPLE: remote keypads). Time when signal/message applied. Time when notification occurs. Record the event log.	GENERAL CRITERIA Processing shall be in accordance with EN 50131-1:2006, Table 7 and 8.4.1. The indications and notifications shall be in accordance with EN 50131-1:2006, Tables 8, 9 and 10	P
1	CIE in "set mode"	Apply fault Signal or message for 10.1 s	-CIE "AC Loss" was applied. -Fault message shown on keypad's events indicators. -Event log recorded the fault	General criteria + Notification shall occur within the time specified by EN 50131-1:2006, 8.9. The logging shall be in accordance with 8.10.	P
2	CIE in "set mode" (with fault condition)	Unset the CIE	Fault is indicated by appropriate mark on the keypad	General criteria. Indications shall comply with 8.5.	P



Test specification: Processing of fault signals or messages test			
Test procedure:		EN 50131-3 TEST METHOD: 11.4.4 Processing of fault signals or messages	
Test mode:		Compliance	
Test Date:		4/8/22	
Atmospheric conditions during the test:		Temperature: 24.2 °C	Air Pressure: 10004 hPa
Remarks:		Relative Humidity: 52 %	
Verdict: PASS			

3	CIE in "unset mode"	Restore	Fault conditions are restored In the moment the battery power is established.	In accordance with 8.3.5	P
4	CIE in "set mode" NOTE To verify that repetitive fault signals or messages are recorded in the event log as required by EN 50131-1:2006, 8.10	Apply the same fault signal or message for 10.1 s once more than the maximum permitted by EN 50131-1:2006, 8.10. Afterwards repeat step 3.	"AC Loss" was applied. Limited by programmable function to 5 events from the same source. -Event log stopped logging after 5 fault signals from the same source	The number of fault alarms from the same source shall be as specified in EN 50131-1:2006, 8.10.	P
5	CIE in "unset mode"	Apply fault signal or message for 10.1 s.	- "AC Loss" was applied. -"Battery Low/failure" logged in event log. - The event was notified to ARC	General criteria	P
6	CIE in "unset mode" NOTE To verify that repetitive fault signals or messages are recorded in the event log as required by EN 50131-1:2006, 8.10.	Apply the same fault signal or message for 10.1 s once more than the maximum permitted by EN 50131-1:2006, 8.10. Afterwards repeat step 3.	"AC Loss" was applied. Limited by programmable function to 5 events from the same source. -Event log stopped logging after 5 fault signals from the same source	The number of fault alarms recorded from the same source shall be as specified in EN 50131-1:2006, 8.10.	P
7	CIE in "set mode". NOTE To verify that if repetitive fault signals or messages are applied, at least one is processed correctly.	Apply 5 fault signals or messages (or the maximum possible number the EUT can recognize if less than 5) within 1 s.	5 fault signals were applied: Loss of EPS , CP control panel fault, Zone open (Magnet detector), PIR tamper opened, keypad tamper opened. - Four faults messages were processed.	At least one fault signal or message shall be processed in accordance with 8.4.1.2 and 8.9.	P



Test specification: Processing of fault signals or messages test			
Test procedure:		EN 50131-3 TEST METHOD: 11.4.4 Processing of fault signals or messages	
Test mode:		Compliance	
Test Date:		4/8/22	
Atmospheric conditions during the test:		Temperature: 24.2 °C	Air Pressure: 10004 hPa
Remarks:		Verdict: PASS Relative Humidity: 52 %	

8	CIE in "set mode" (with more than one fault condition)	Unset the CIE.	- The faults still appear on the keypad as troubles until restored by the user	General criteria Indications shall comply with 8.5.1.1.	P
9	CIE in "unset mode"	Restore all the conditions.	-The system is restored by entering the correct user code	In accordance with 8.3.5	P
10	CIE in "set mode"	Apply at least one of each of intruder, hold-up, tamper and fault signals or messages equivalent to 5 % of the maximum alarm point capacity of the CIE or 5 (whichever is the greater) within 1 s.	All conditions, indicated logged and notified	General criteria + Notification should be in accordance with 8.4.1. All the conditions shall be correctly identified and logged in the event log at the correct time.	P
11	CIE in "unset" mode Enable EPS Fault notification delay required by 8.6.	Apply "EPS Fault" signal or message.	- AC fault was applied. - "AC Fail" logged in event log. - The event was notified to ARC	Notification of the fault shall be delayed as required by 8.6.	P
12	As step 11, during delay period	Remove "EPS Fault" signal or message.	- AC fault was restored.	Notification shall be cancelled according to 8.6.	P

7.5.4 Results

(X) The above results comply with this section of the standard.

(...) The above results do not comply with this section of the standard.

Reference numbers of test equipment used

HL 2772	HL 3460
---------	---------

Full description is given in Appendix A.



Test specification:		Access level test	
Test procedure:		EN 50131-3 TEST METHOD: 11.5.1 Access to the functions and controls	
Test mode:	Compliance	Verdict:	PASS
Test Date:	4/8/22		
Atmospheric conditions during the test:	Temperature: 24.2 °C	Air Pressure: 1004hPa	Relative Humidity: 52 %
Remarks:			

7.6 Access level test procedure and results

7.6.1 Test purpose

To demonstrate the ability of the CIE to comply with 8.1.5, 8.3.1, 8.3.3.1, 8.3.5, 8.3.6, 8.3.7, 8.3.9, 8.4.2 and 8.10 to provide up to four levels of access and verify the relevant access to the functions and controls.

7.6.2 Test procedure

7.6.2.1 The tests shall be performed with the CIE in set and unset modes and one or more optional signals or messages are present.

7.6.2.2 Attempt to use the functions and the controls required by 8.1.5, 8.3.1, 8.3.3.1, 8.3.5, 8.3.6, 8.3.7, 8.3.9, 8.4.2 and 8.10, operating the CIE at each access level and verifying that access is granted for permitted functions and is denied for non-permitted functions.

7.6.2.3 The results were documented as presented in Table 7.6.1.

7.6.3 Test results

Table 7.6.1 Test results

Step	Test Condition	Action	Measurement	Pass criteria	Verdict
1	The CIE and any necessary ACE shall be mounted according to the manufacturer's specifications.	At access level 1 attempt to operate all the functions and controls listed in 8.3.6, 8.3.7 and 8.3.9 and in EN 50131-1:2006, Tables 2, 5, 6 and 8 and 8.3.10.	Access level 1: No one can interrogate system errors, device errors, bypassed zones without level 2 authorization Not permitted to change arm/disarm or system configuration	Access is in accordance with 8.3.9 and EN 50131-1:2006, Tables 2, 5, 6 and 8.	P
2	As above	Repeat as step 1 for access level 2.	Permitted to activate all authorized functions Access not permitted for the functions programmed by Master/Installer User	As above	P
3	As above	Repeat as step 1 for access level 3.	As above Installer access (level 3) is permitted only with the authorization of level 2	As above	P
4	As above	Repeat as step 1 for access level 4.	Can be considered the manufacturer	As above	P



Test specification:		Access level test	
Test procedure:		EN 50131-3 TEST METHOD: 11.5.1 Access to the functions and controls	
Test mode:		Compliance	
Test Date:		4/8/22	
Atmospheric conditions during the test:		Temperature: 24.2 °C	Air Pressure: 1004hPa
Remarks:		Verdict: PASS	
		Relative Humidity: 52 %	

			action to implement a new SW version		
NOTE: If means is provided to gain level 3 access without level 2 authorization (see EN 50131-1:2006, 8.3.1), not permitted at grade 4:					
5	CIE unset	Enter level 3 access code or key	Level 3 user cannot gain access without level 2 authorization	Notified by internal WD and (grade 2 and 3) remotely	N/A
6	Perform action defined by manufacturer to silence WD or allow to time out, as applicable	-	As above	WD silenced. Level 3 access obtained	N/A
7	CIE set	Repeat steps 5 and 6	As above	No response, remains at level 1 access	N/A

7.6.4 Results

(X) The above results comply with this section of the standard.

(...) The above results do not comply with this section of the standard.

Reference numbers of test equipment used

HL 2772	HL 3460
---------	---------

Full description is given in Appendix A.



Test specification:		PIN code test	
Test procedure:		EN 50131-3 TEST METHOD: 11.6.2.2 PIN code	
Test mode:	Compliance	Verdict:	PASS
Test Date:	4/8/22		
Atmospheric conditions during the test:	Temperature: 24.2 °C	Air Pressure: 1004hPa	Relative Humidity: 52 %
Remarks:			

7.7 PIN code test procedure and results

7.7.1 Test purpose

To verify that the range of variations of PIN codes is provided and that invalid codes are not accepted.

7.7.2 Test procedure

7.7.2.1 Create samples of valid codes as described in the CIE documentation. The number of valid codes to be created shall be: 10 for grade 1; 20 for grade 2; 50 for grade 3; 100 for grade 4.

7.7.2.2 Attempt to create an invalid code.

7.7.2.3 Verify the validity of the manufacturer's calculations.

7.7.2.4 The results were documented as presented in Table 7.7.1.

7.7.3 Test results

Table 7.7.1 Test results

Step	Test Condition	Action	Measurement	Pass criteria	Verdict
1	For the test purpose, the manufacturer shall provide to the test house the following information: 1) The number of disallowed codes; 2) The method used to determine the number of variations; 3) For each user, the minimum number of variations of logical key shall be indicated.	Record the valid codes.	-The valid codes created can accepted to arm/disarm -All codes are 4 digits long exactly -Each digit can be 0-9 So the total number of options: $Z=10^4 = 10000$ - Disallowed code: 0000 - One master installer (0001 by default)*. One installer (1234 by default)* * Codes must not be identical	All valid codes shall be accepted according to grade.	P



Test specification:		PIN code test	
Test procedure:		EN 50131-3 TEST METHOD: 11.6.2.2 PIN code	
Test mode:		Compliance	
Test Date:		4/8/22	
Atmospheric conditions during the test:		Temperature: 24.2 °C	Air Pressure: 1004hPa
Remarks:		Verdict: PASS Relative Humidity: 52 %	

			-Correct codes were created as required.		
2	As above	Record the invalid code.	- 2345 was not a code from the 20 codes that programmed. - When tried this code it was not accepted.	Invalid codes shall not be accepted.	P

7.7.4 Results

- (X) The above results comply with this section of the standard.
- (...) The above results do not comply with this section of the standard.

Reference numbers of test equipment used

HL 2772	HL 3460
---------	---------

Full description is given in Appendix A.



Test specification:		Invalid authorization attempts test	
Test procedure:		EN 50131-3 TEST METHOD: 11.6.3 Invalid authorization attempts	
Test mode:	Compliance	Verdict:	PASS
Test Date:	4/8/22		
Atmospheric conditions during the test:	Temperature: 24.2 °C	Air Pressure: 1004 hPa	Relative Humidity: 52 %
Remarks:			

7.8 Invalid authorization attempts test procedure and results

7.8.1 Test purpose

To verify that the detection and notification of attempted entry of invalid logical keys or (when the CIE has the means to distinguish such) mechanical keys complies with 8.3.2 and Table 3.

7.8.2 Test procedure

7.8.2.1 Enter a series of invalid logical or (if appropriate) mechanical keys and establishing that when the number of invalid attempts have been made as specified in Table 3 the user input device is disabled and/or a tamper signal or message is generated and recorded in the event log as specified.

7.8.2.2 Verify the validity of the manufacturer's calculations.

7.8.2.3 The results were documented as presented in Table 7.8.1 and/or 7.8.2.

7.8.3 Test results

Table 7.8.1 Test results for disabling user input device by invalid keys

Step	Test Condition	Action	Measurement	Pass criteria	Verdict
If the CIE has the facility to disable user input device carry out this series of tests					
	GENERAL: The CIE shall be configured with its inputs and outputs in their normal condition, allowing the CIE to be set and alarms to be generated from at least 1 alarm point.	GENERAL: The steps 2,4, 5, 6 and 7 shall be repeated in the "UNSET" mode of the CIE.	Repeated for unset mode	As below	P
1	CIE unset	Enter a valid key and attempt to set CIE.	System set. red led indication at the keypad	CIE set	P
2	CIE set	Enter a series of invalid keys according to Table 1 to attempt to initially disable the user input device.	After 5 invalid code entries, the user input device disabled for 100 sec. Indication at the keypad.	CIE should not change state, the generation of tamper conditions and event log shall be in accordance with Table 1.	P
3	CIE set	During the "disabling time" apply an alarm signal or message.	- Alarm condition is processed.	The alarm generated during the	P



Test specification:		Invalid authorization attempts test	
Test procedure:		EN 50131-3 TEST METHOD: 11.6.3 Invalid authorization attempts	
Test mode:	Compliance	Verdict:	PASS
Test Date:	4/8/22		
Atmospheric conditions during the test:	Temperature: 24.2 °C	Air Pressure: 1004 hPa	Relative Humidity: 52 %
Remarks:			

			- Siren was activated	disable period shall be processed in accordance with EN 50131-1:2006, Table 7 and 8.4.1.	
4	CIE set	During the “disabling time” try to enter a valid key.	- No response, device disabled.	The CIE shall not change state. The user input device shall remain disabled.	P
5	CIE set	When disabling time has expired, enter another series of invalid keys according to Table 4.	- User input device disabled after 5 invalid code entries.	The CIE shall not change state and shall be in accordance with Table 4.	P
6	CIE set	During the “disabling time” try to enter a valid key.	- No response, device disabled.	The CIE shall not change state. The user input device shall remain disabled.	P
7	CIE set	When disabling time has expired enter a valid key and attempt to change state of the CIE.	- After the user is introducing the user code, CP disarmed green indication icon at the keypad	The CIE shall change state.	P



Test specification:		Invalid authorization attempts test	
Test procedure:		EN 50131-3 TEST METHOD: 11.6.3 Invalid authorization attempts	
Test mode:		Compliance	
Test Date:		4/8/22	
Atmospheric conditions during the test:		Temperature: 24.2 °C	Air Pressure: 1004 hPa
Remarks:		Verdict: PASS	
		Relative Humidity: 52 %	

Table 7.8.2 Test results for generation of tamper by invalid keys

Step	Test Condition	Action	Measurement	Pass criteria	Verdict
If the CIE has the facility in accordance with Table 1 to generate a tamper, carry out this series of tests					
	GENERAL: The CIE shall be configured with its inputs and outputs in their normal condition, allowing the CIE to be set and alarms to be generated from at least 1 alarm point.	GENERAL: The steps 2 and 3 shall be repeated in the "UNSET" mode of the CIE.	Repeated for unset mode	As below	P
1	CIE unset	Enter a valid key and attempt to set CIE.	Set completed.	CIE set	P
2	CIE set	Enter a series of invalid keys according to Table 4 to attempt to initially disable the user input device.	After 5 invalid code entries, special tamper message was displayed in the event log. - "Keypad locked" indication at the keypad.	CIE shall not change state, the generation of tamper conditions and event log shall be in accordance with Table 1.	P
3	CIE set	Enter a valid key to acknowledge the tamper condition.	Tamper acknowledged.	The tamper condition shall be acknowledged and shall be in accordance with Table 1.	P

7.8.4 Results

(X) The above results comply with this section of the standard.

(...) The above results do not comply with this section of the standard.

Reference numbers of test equipment used

HL 2772	HL 3460
---------	---------

Full description is given in Appendix A.



Test specification:		Setting procedures test	
Test procedure:		EN 50131-3 TEST METHOD: 11.7.1 Setting procedures	
Test mode:	Compliance	Verdict:	PASS
Test Date:	4/8/22		
Atmospheric conditions during the test:	Temperature: 24.2 °C	Air Pressure: 1004 hPa	Relative Humidity: 52 %
Remarks:			

7.9 Setting procedures test procedure and results

7.9.1 Test purpose

To verify that all setting procedures are in accordance with 8.3.3, 8.3.3.2 and 8.3.3.3

7.9.2 Test procedure

7.9.2.1 Set the CIE and verifying that these are in accordance with the requirements of the standard.

7.9.2.2 The results were documented as presented in Table 7.9.1.

7.9.3 Test results

Table 7.9.1 Test results

Step	Test Condition	Action	Measurement	Pass criteria	Verdict
	GENERAL CONDITION The CIE is in "unset" condition. For the purpose of this series of tests The keys and/or codes shall be selected to have the necessary authorisations for "inhibit" and "override" functions.		GENERAL: Record the CIE condition	GENERAL CRITERIA When the CIE fails to set, means shall be provided to indicate or notify. If the indication of the set state is provided, it shall be time- limited according to EN 50131-1:2006, 8.3.7. The logging shall be in accordance with 8.10.	P
Complete the following series of tests for each setting method given in the manufacturer's documentation.					
1	CIE is unset	Initiate exit procedure.	Exit procedure indicated, time countdown displayed on the keypad	The CIE shall set and indicate accordingly.	P
2	CIE unset	Setting procedure initiated but prevented from completion "Fail to set" time expires	- Fail to set indicated on the keypad. - The unit does not set Indication for user that system failed to set.	Incomplete exit condition indicated and/or notified, according to 8.3.3.3 CIE not set. No alarm notification.	P



Test specification:		Setting procedures test	
Test procedure:		EN 50131-3 TEST METHOD: 11.7.1 Setting procedures	
Test mode:		Compliance	
Test Date:		4/8/22	
Atmospheric conditions during the test:		Temperature: 24.2 °C	Air Pressure: 1004 hPa
Remarks:		Verdict: PASS	
		Relative Humidity: 52 %	

			- No alarm notification		
For CIE where setting using exit route is possible, verify that means exists to select alarm points to be included in exit route facility and:					
3	CIE unset	Start the setting procedure (exit time).	Setting procedure correctly initiated and indicated	The setting procedure shall be initiated and indicated according to 8.3.3.2 and EN 50131-1:2006, Tables 8 and 9.	P
4		Activate an exit route alarm point, during the exit time period.	No Alarm notification	The activated alarm point shall not cause alarm notification.	P
5		Ensure the alarm point is no longer in the activated condition. Allow the setting procedure to complete or complete setting procedure as appropriate to method.	Set completed	The setting procedure shall be completed. CIE is set, in accordance with 8.3.3.2.	P
6	CIE unset Exit procedure initiated Exit route alarm point activated	Exit route alarm point remains activated Exit time or "Fail to set" time expires	- Fail to set indicated on keypad. - The unit does not set - No alarm notification	Incomplete exit condition indicated and/or notified, according to 8.3.3.3 CIE not set. No alarm notification	P
For CIE including facility to set by level 1 access, as permitted by EN 50131-1:2006, 8.3.4 (grade 1 only):					
7	CIE is unset,	Initiate level 1 setting in accordance with manufacturer's instructions.	Grade 2	The CIE operation shall commence setting procedure.	N/A
8	During setting procedure	Operate level 1 "cancel setting" in accordance with manufacturer's instructions.	As above	The CIE shall cancel the setting procedure and remain unset.	N/A
9	CIE is unset	Initiate level 2 setting in accordance with manufacturer's instructions.	As above	The CIE operation shall commence setting procedure.	N/A
10	During setting procedure	Operate level 1 "cancel setting" in accordance with manufacturer's instructions.	As above	The CIE shall continue the setting procedure. Allow to set.	N/A



Test specification:		Setting procedures test	
Test procedure:		EN 50131-3 TEST METHOD: 11.7.1 Setting procedures	
Test mode:		Compliance	
Test Date:		4/8/22	
Atmospheric conditions during the test:		Temperature: 24.2 °C	Air Pressure: 1004 hPa
Remarks:		Verdict: PASS	
		Relative Humidity: 52 %	

11	CIE is set	Operate level 1 "cancel setting" in accordance with manufacturer's instructions.	As above	The CIE shall remain set.	N/A
----	------------	--	----------	---------------------------	-----

7.9.4 Results

- (X) The above results comply with this section of the standard.
- (...) The above results do not comply with this section of the standard.

Reference numbers of test equipment used

HL 2772	HL 3460
---------	---------

Full description is given in Appendix A.



Test specification:		Prevention of setting and overriding of prevention of setting procedures test	
Test procedure:		EN 50131-3 TEST METHOD: 11.7.2 Prevention of setting and overriding of prevention of setting procedures	
Test mode:		Compliance	
Test Date:		7/8/22	
Atmospheric conditions during the test:		Temperature: 25.7 °C	Air Pressure: 1001hPa
Remarks:		Verdict: PASS Relative Humidity: 46 %	

7.10 Prevention of setting and overriding of prevention of setting test procedure and results

7.10.1 Test purpose

To verify that all procedures are in accordance with 8.3.3.1

7.10.2 Test procedure

7.10.2.1 Attempt setting the CIE and verifying that the responses are in accordance with the requirements of this standard.

7.10.2.2 The results were documented as presented in Table 7.10.1.

7.10.3 Test results

Table 7.10.1 Test results

Step	Test Condition	Action	Measurement	Pass criteria	Verdict
	GENERAL CONDITION The CIE is in "unset" condition. For the purpose of this series of tests The keys and/or codes shall be selected to have the necessary authorisations for "inhibit" and "override" functions.	Provision of override of prevention of setting function and inhibit function described in the test are not mandatory (8.3.3.1 and 8.3.6).	GENERAL: Record the CIE condition.	GENERAL CRITERIA When the CIE fails to set, means shall be provided to indicate or notify. If the indication of the set state is provided, it shall be time- limited according to EN 50131-1:2006 8.3.7. The logging shall be in accordance with 8.10.	P
Complete the following series of tests for each setting method given in the manufacturer's documentation and for each condition specified in EN 50131-1:2006, Table 4.					
1	Alarm point (not allocated to an exit route) in active condition CIE unset	Try to set the system.	- Setting prevented. - CIE remain unset	The setting procedure shall be in accordance with 8.3.3 and EN 50131-1:2006, Table 4.	P
2	Alarm point (not allocated to an exit route) in active condition. Setting prevented` (see step 1) CIE unset	Inhibit the active alarm point (if function provided) – see 8.3.6. Try to set the system.	- Zone open - Zone bypass by access level 2. (Force Arm) - CIE set	The setting procedure shall continue in accordance with EN 50131-1:2006, Table 4 and be completed	P



Test specification:		Prevention of setting and overriding of prevention of setting procedures test	
Test procedure:		EN 50131-3 TEST METHOD: 11.7.2 Prevention of setting and overriding of prevention of setting procedures	
Test mode:		Compliance	
Test Date:		7/8/22	
Atmospheric conditions during the test:		Temperature: 25.7 °C	Air Pressure: 1001hPa
Remarks:		Verdict: PASS	
		Relative Humidity: 46 %	

				according to manufacturer's instructions.	
3	The CIE in "unset" condition. Tamper signal or message applied to the CIE	Try to set the system.	- Setting prevented. - CIE remain unset	The setting procedure shall be prevented in accordance with EN 50131-1:2006, Table 4	P
4	Setting prevented (see step 3) CIE unset	Override the tamper (if function provided) – see EN 50131-1:2006 Table 5. Try to set the system.	-Setting prevented. - Tamper bypass by access level 2. (Force Arm)	The setting procedure shall continue in accordance with EN 50131-1:2006, Table 4 and be completed according to manufacturer's instructions.	P
5	The CIE is in "unset" condition. Hold-up signal or message applied to the CIE	Try to set the system.	- Setting prevented. - CIE remain unset	The setting procedure shall be prevented in accordance with EN 50131-1:2006, Table 4.	P
6	Setting prevented (see step 5) CIE unset	Inhibit the hold-up device (if function provided) – see 8.3.6. Try to set the system.	- Hold up signal bypass by access level 2. (Force Arm)	The setting procedure shall continue in accordance with EN 50131-1:2006, Table 4 and be completed according to manufacturer's instructions.	P
For movement detector masking, movement detector range reduction and each fault signal or message specified in EN 50131-1:2006, Table 4 repeat steps 7 and 8.					
7	The CIE is in "unset" condition. Apply fault signal or message to CIE.	Try to set the system.	- "AC Fail". - Setting prevented. - CIE remain unset	The setting procedure shall be prevented in accordance with EN 50131-1:2006, Table 4.	P
8	Setting prevented (see step 7) CIE unset	Override the setting prevention (if function provided) – see 8.3.6.	- ""AC Fail". - Fault bypass by access level 2. (Force Arm) - CIE set	The setting procedure shall continue in accordance with EN 50131-1:2006, Table 4 and be completed according to	P



Test specification:		Prevention of setting and overriding of prevention of setting procedures test	
Test procedure:		EN 50131-3 TEST METHOD: 11.7.2 Prevention of setting and overriding of prevention of setting procedures	
Test mode:	Compliance	Verdict:	PASS
Test Date:	7/8/22		
Atmospheric conditions during the test:	Temperature: 25.7 °C	Air Pressure: 1001hPa	Relative Humidity: 46 %
Remarks:			

				manufacturer's instructions.	
--	--	--	--	------------------------------	--

7.10.4 Results

- (X) The above results comply with this section of the standard.
- (...) The above results do not comply with this section of the standard.

Reference numbers of test equipment used

HL 2772	HL 3460
---------	---------

Full description is given in Appendix A.



Test specification:		Unsetting procedures test	
Test procedure:		EN 50131-3 TEST METHOD: 11.7.4 Unsetting procedures	
Test mode:		Compliance	
Test Date:		7/8/22	
Atmospheric conditions during the test:		Temperature: 25.7 °C	Air Pressure: 1001 hPa
Remarks:		Verdict: PASS	
		Relative Humidity: 46 %	

7.11 Unsetting test procedure and results

7.11.1 Test purpose

To verify that all procedures are in accordance with the requirements of 8.3.4

7.11.2 Test procedure

7.11.2.1 Unset the CIE using all the procedures provided as specified in the manufacturer’s documentation and verification that these are in accordance with the requirements within this specification

7.11.2.2 The results were documented as presented in Table 7.11.1.

7.11.3 Test results

Table 7.11.1 Test results

Step	Test Condition	Action	Measurement	Pass criteria	Verdict
	GENERAL CONDITION The CIE is in “set” condition. The keys and the codes used are all valid with the necessary authority.		GENERAL: Record the CIE condition.	GENERAL CRITERIA The indication of the unset state shall be time-limited according to EN 50131-1:2006, 8.3.8.2. The logging shall be in accordance with 8.10.	P
Complete the following series of tests for each unsetting method provided in the manufacturer’s documentation.					
1	CIE set, in a normal condition with no alarms or, tampers activated.	Try to manually unset the system.	Unsetting procedure completed.	The unsetting procedure shall be completed.	P
2	CIE set. Alarm point (not on an agreed entry route) in active condition	Try to manually unset the system.	Unsetting procedure completed, correct indication, notification and event recording.	The unsetting procedure shall be completed. Notification, indication and event recording shall comply with EN 50131-1:2006, Tables 7, 8, 9 and 22.	P
For CIE with entry route facility, complete the following series of tests for each unsetting method provided in the manufacturer’s documentation.					
3	CIE set	Manually start the unsetting procedure (entry time).	- Entry time started - Keypad indication - Correct entry	The unsetting procedure shall be initiated. Indication shall be in accordance	P



Test specification:		Unsetting procedures test	
Test procedure:		EN 50131-3 TEST METHOD: 11.7.4 Unsetting procedures	
Test mode:		Compliance	
Test Date:		7/8/22	
Atmospheric conditions during the test:		Temperature: 25.7 °C	Air Pressure: 1001 hPa
		Relative Humidity: 46 %	
Remarks:			

			indication by Beep sound and event recording	with EN 50131-1:2006, 8.3.8.2 and Tables 8 and 9 and recorded in the event log in accordance with EN 50131-1:2006, Table 22.	
4	CIE set	Manually start the unsetting procedure (Entry time).	Unsetting procedure initiated	The unsetting procedure shall be initiated.	P
5		Generate an intruder alarm from an entry route alarm point.	Alarm not notified	An intruder alarm shall not be notified.	P
6		Do not complete the unsetting procedure (let the entry time expire).	- Alarm condition notified. - Siren was activated	An alarm condition shall be Notified according to EN 50131-1:2006, 8.3.8.2.	P
7	CIE set	Manually start the unsetting procedure (Entry time).	- Entry time started - Indication by Beep sound and event recording	The unsetting procedure shall be initiated. Indication shall be in accordance with EN 50131-1:2006, 8.3.8.2 and Tables 8 and 9.	P
8	Unsetting procedure in process	Generate an intrusion alarm from an entry route alarm point and complete the entry procedure.	- Intruder alarm not processed. - Correct entry indication by Beep sound and event recording	CIE is unset. The intruder alarm shall not be processed. A correct entry procedure shall be indicated as per EN 50131-1:2006, 8.3.8.2 and Tables 8 and 9, and recorded in the event log in accordance with EN 50131-1:2006, Table 22.	P
9	CIE set	Manually start the unsetting procedure (Entry time).	- Entry time started	The unsetting procedure shall be initiated.	P
10		Generate a tamper alarm from an entry route alarm point.	- Tamper alarm notified	The tamper alarm shall be notified.	P



Test specification:		Unsetting procedures test	
Test procedure:		EN 50131-3 TEST METHOD: 11.7.4 Unsetting procedures	
Test mode:		Compliance	
Test Date:		7/8/22	
Atmospheric conditions during the test:		Temperature: 25.7 °C	Air Pressure: 1001 hPa
		Relative Humidity: 46 %	
Remarks:			

			- Siren was activated		
11	CIE set	Manually start the unsetting procedure (entry time).	- Entry time started	The unsetting procedure shall be initiated.	P
12		Generate an intrusion alarm from a non-entry route alarm point.	Indication and siren output activation	Indication or Warning Device shall be activated in accordance with EN 50131-1:2006, 8.3.8.2.	P
13	Unsetting is proceeding	Wait for expiry of time programmed or specified by manufacturer after indication or internal WD activated. MINIMUM time is 30 s	By proper installer entry delay and cancel alarm settings Notification delayed as required	Where remote notification devices are connected, ensure this is not activated prior to the completion of the delay required by EN 50131-1:2006, 8.3.8.2.	P
14	CIE set	Manually start the unsetting procedure (Entry time).	- Entry time started	The unsetting procedure shall be initiated.	P
15		Do not complete the unsetting procedure (let the entry time expire).	- Alarm notified	The alarm shall be notified in accordance with EN 50131-1:2006, 8.3.8.2.	P
16	CIE set	Manually start the unsetting procedure (Entry time).	- Entry time started	The unsetting procedure shall be initiated.	P
17		Generate an alarm from a non-entry route alarm point.	Intruder alarm processed and indicated on the keypad.	Indication or Warning Device shall be activated in accordance with EN 50131-1:2006, 8.3.8.2.	P
18		Complete the unsetting procedure before the notification delay expires, see paragraph 3 of EN 50131-1:2006, 8.3.8.2.	Unset, No any notification.	The indicator or warning devices shall be restored and remote notification shall not take place. The CIE shall be unset.	P

Results

(X) The above results comply with this section of the standard.

(...) The above results do not comply with this section of the standard.

Reference numbers of test equipment used

HL 2772	HL 3460
---------	---------

Full description is given in Appendix A.



Test specification: Setting and/or unsetting automatically at pre-determined times test			
Test procedure: EN 50131-3 TEST METHOD: 11.7.5 Setting and/or unsetting automatically at pre-determined times			
Test mode: Compliance		Verdict: PASS	
Test Date: 7/8/22			
Atmospheric conditions during the test:	Temperature: 25.7 °C	Air Pressure: 1001 hPa	Relative Humidity: 46 %
Remarks:			

7.12 Setting and/or unsetting automatically at pre-determined times test procedure and results

7.12.1 Test purpose

To verify that all procedures are in accordance with 8.3.3, 8.3.3.1 and 8.3.4

7.12.2 Test procedure

7.12.2.1 Attempt setting the CIE and verifying that the responses are in accordance with the requirements of this standard.

7.12.2.2 The results were documented as presented in Table 7.12.1.

7.12.3 Test results

Table 7.12.1 Test results

Step	Test Condition	Action	Measurement	Pass criteria	Verdict
	GENERAL CONDITION The CIE is in "unset" condition. For the purpose of this series of tests The keys and/or codes shall be selected to have the necessary authorisations for "inhibit" and "override" functions.	Provision of override of prevention of setting function and inhibit function described in the test are not mandatory (8.3.3.1 and 8.3.6).	GENERAL: Record the CIE condition.	GENERAL CRITERIA When the CIE fails to set, means shall be provided to indicate or notify. If the indication of the set state is provided, it shall be time- limited according to EN 50131-1:2006, 8.3.7. The logging shall be in accordance with 8.10.	P
If CIE has facility for setting automatically:					
1	CIE is unset, prior to time that pre-setting indication is scheduled.	Allow automatic sequence to operate.	- Automatic setting procedure initiated - Setting entered in event log: "Auto arming" - No override function identified	Pre-setting indication available as documented manufacturer. Setting and override of Prevention of set shall be entered in event log.	P
2	With CIE set, create alarm.	Allow automatic unset to take place.	No automatic unset.	Unsetting takes place as scheduled. Alert indication present.	N/A



Test specification:		Setting and/or unsetting automatically at pre-determined times test	
Test procedure:		EN 50131-3 TEST METHOD: 11.7.5 Setting and/or unsetting automatically at pre-determined times	
Test mode:		Compliance	
Test Date:		7/8/22	
Atmospheric conditions during the test:		Temperature: 25.7 °C	Air Pressure: 1001 hPa
		Relative Humidity: 46 %	
Remarks:			

				Unsetting entered in event log	
3		Obtain level 2 access.	level 2 access Obtained.	Correct record of alarm created whilst set. Alarm is present in event log.	P
4	CIE is unset, prior to time pre-setting indication is scheduled. Condition to prevent setting present	Allow automatic sequence to operate.	- Automatic setting prevented - No overriding possible - "Arm Fail" recorded in event log	Pre-setting indication available as documented manufacturer. Setting prevented or prevention of setting automatically overridden. Setting and override of prevention of set shall be entered in event log.	P
If CIE has provision for automatic unsetting:					
5	CIE set	Initiate unsetting sequence in accordance with manufacturer's instructions.	No automatic unsetting	The unsetting procedure shall be completed.	N/A
6	CIE set and in alarm condition	Initiate unsetting sequence in accordance with manufacturer's instructions	As above	The unsetting procedure shall be completed. The alarm condition shall not be cancelled. Alarm event and unsetting shall be entered in event log.	N/A

7.12.4 Results

(X) The above results comply with this section of the standard.

(...) The above results do not comply with this section of the standard.

Reference numbers of test equipment used

HL 2772	HL 3460
---------	---------

Full description is given in Appendix A.



Test specification:		Availability of Indications test	
Test procedure:		EN 50131-3 TEST METHOD: 11.7.10 Availability of Indications	
Test mode:		Compliance	
Test Date:		7/8/22	
Atmospheric conditions during the test:		Temperature: 25.7 °C	Air Pressure: 1001 hPa
Remarks:		Verdict: PASS	
		Relative Humidity: 46%	

7.13 Availability of indications test procedure and results

7.13.1 Test purpose

To demonstrate the ability of the CIE to comply with the requirements of 8.5.1

7.13.2 Test procedure

7.13.2.1 Introduce a condition requiring a mandatory indication and ensuring that the requirements of EN 50131-1:2006, 8.5.2 and 8.5.3 are met, in accordance with Table 7.13.1.

7.13.3 Test results

Table 7.13.1 Test results

Step	Test Condition	Action	Measurement	Pass criteria	Verdict
1	The CIE shall be in the unset mode, with all inputs and outputs in normal condition.	Induce a fault requiring mandatory indication according to EN 50131-1:2006, Table 8.	- AC Fail - Indication on the keypad	Alert indication present	P
2	Gain access to CIE at level 2.	View information displayed.	Fault message displayed at the event log.	Correctly indicates fault condition generated.	P
3	Return to level 1 access in accordance with manufacturer's specification – using automatic (timed) response if provided.	View information displayed.	Fault message presented	Alert indication present If automatic (timed) action, it is performed within time limit specified by manufacturer.	P
4	Remove the fault condition applied at step 1.	View information displayed.	Fault message presented	Alert indication present	P
5	Gain access to CIE at level 2.	View information displayed.	Indication of the fault condition remains available.	Indication of the fault condition remains available.	P
6	Return to access level 1 and restore.	View information displayed.	Trouble Indication does not change until acknowledged	No indication	P



Test specification:		Availability of Indications test	
Test procedure:		EN 50131-3 TEST METHOD: 11.7.10 Availability of Indications	
Test mode:		Compliance	
Test Date:		7/8/22	
Atmospheric conditions during the test:		Temperature: 25.7 °C	Air Pressure: 1001 hPa
Remarks:		Verdict: PASS	
		Relative Humidity: 46%	

7.13.4 Results

- (X) The above results comply with this section of the standard.
- (...) The above results do not comply with this section of the standard.

Reference numbers of test equipment used

HL 2772	HL 3460
---------	---------

Full description is given in Appendix A.



Test specification:		Tamper protection test	
Test procedure:		EN 50131-3 TEST METHOD: 11.8.2 Tamper protection	
Test mode:		Compliance	
Test Date:		7/8/22	
Atmospheric conditions during the test:		Temperature: 25.7 °C	Air Pressure: 1001 hPa
Remarks:		Verdict: PASS Relative Humidity: 46 %	

7.14 Tamper protection test procedure and results

7.14.1 Test purpose

To use Impact testing to verify that the CIE/ACE housing meets the tamper protection requirements of 8.7.1.

7.14.2 Test procedure

7.14.2.1 The CIE/ACE was installed in their operational position.

7.14.2.2 The CIE/ACE housing was subjected to impacts from a small hemispherical hammer-head on any exposed surfaces of the EUT.

7.14.2.3 A visual inspection following by a reduced functional test was performed after the impact test

7.14.2.4 The results were documented as presented in Table 7.14.1.

7.14.3 Test results

Table 7.14.1 Test results

Observation	Verdict
<ul style="list-style-type: none"> - CIE tested with impacts of 1 Joule (3 impacts per point at each exposed surface) - The EUT meet the requirements of the reduced functional test before, during and after the test. - No structural or mechanical damages were registered during the visual inspection. - The EUT passed the impact test. 	P

Note: investigated under 50130-5:2011 standard.

7.14.4 Results

(X) The above results comply with this section of the standard.

(...) The above results do not comply with this section of the standard.

Reference numbers of test equipment used

HL 2772	HL 3460	HL 3013
---------	---------	---------

Full description is given in Appendix A.



Test specification: Tamper detection - Access to the inside of the housing test			
Test procedure:		EN 50131-3 TEST METHOD: 11.8.3 Tamper detection - Access to the inside of the housing	
Test mode:		Compliance	
Test Date:		7/8/22	
Atmospheric conditions during the test:		Temperature: 25.7 °C	
		Air Pressure: 1001 hPa	
		Relative Humidity: 46 %	
Remarks:			
		Verdict: PASS	

7.15 Tamper detection - Access to the inside of the housing procedure and results

7.15.1 Test purpose

To verify that it is not possible to insert a tool into the CIE/ACE in its normal mounting position and defeat the operation of the tamper detection circuitry before a tamper signal or message is generated.

7.15.2 Test procedure

7.15.2.1 Mount the CIE/ACE according to the manufacturer's instructions with the housing securely closed.

7.15.2.2 Open the CIE/ACE housing by normal means and attempt to introduce a sabotage tool as specified in 8.7.2.1, into the EUT without causing physical damage before the tamper detection device operates.

7.15.2.3 If the tool is successfully inserted, it should be maneuvered to try to interfere with the tamper detection device. The wire test includes forming the wire as appropriate.

7.15.2.4 Attempts shall be restricted to 5 min per tool (10 min for grade 4). If the test fails, it should be repeated and a further failure within 4 further attempts shall result in the overall test failing.

7.15.2.5 The results were documented as presented in Table 7.15.1.

7.15.3 Test results

Table 7.15.1 Test results

Step	Test Condition	Action	Measurement	Pass criteria	Verdict
1	The CIE should be in unset condition.	Open by normal means	Screwdriver required for opening	Opening the CIE/ACE by normal means shall only be possible by following the procedure defined by the manufacturer and shall generate a tamper signal or message.	P
2		Attempt to introduce a sabotage tool by Steel rod.	2.5mm for grade 2 No access without generation of the tamper signal or message		P
3		Attempt to introduce a sabotage tool by Flat bar.	10 x 1 x 300mm for grade 2 No access without generation of the tamper signal or message		The tamper detection device shall not have been defeated before the generation of a tamper signal or message. P



Test specification:		Tamper detection - Access to the inside of the housing test	
Test procedure:		EN 50131-3 TEST METHOD: 11.8.3 Tamper detection - Access to the inside of the housing	
Test mode:	Compliance	Verdict:	PASS
Test Date:	7/8/22		
Atmospheric conditions during the test:	Temperature: 25.7 °C	Air Pressure: 1001 hPa	Relative Humidity: 46 %
Remarks:			

4		Attempt to introduce a sabotage tool by Steel wire.	Not applicable for Grade 2	Visible damage has been caused in order to defeat the tamper detection device.	N/A
---	--	---	----------------------------	--	-----

7.15.4 Results

(X) The above results comply with this section of the standard.

(...) The above results do not comply with this section of the standard.

Reference numbers of test equipment used

HL 2772	HL 3460	HL 3477	HL 4548
---------	---------	---------	---------

Full description is given in Appendix A.



Test specification:		Tamper detection - Removal from mounting test	
Test procedure:		EN 50131-3 TEST METHOD: 11.8.4 Tamper detection - Removal from mounting	
Test mode:		Compliance	
Test Date:		Verdict: N/A	
Atmospheric conditions during the test:	Temperature:	Air Pressure:	Relative Humidity:
Remarks:			

7.16 Tamper detection - Removal from mounting test procedure and results

7.16.1 Test purpose

To remove the CIE/ACE from its mounting surface and monitoring the EUT to determine whether a tamper signal or message is generated within the required time period when the maximum permitted distance (see 8.7.2.2) is exceeded.

7.16.2 Test procedure

7.16.2.1 Position the EUT on a horizontal flat surface, taking into account any requirements specified by the manufacturer to operate the removal from mounting detection device.

7.16.2.2 Lift the EUT from the flat surface in a perpendicular direction to the mounting surface by a distance exceeding that specified in 8.7.2.2, whilst monitoring the tamper signal or message output.

7.16.2.3 Attempt to slide a test blade as defined in 8.7.2.2 to defeat the removal from mounting detection before and during the above test.

7.16.2.4 Attempt to use pliers as specified in 8.7.2.2 to defeat the removal from mounting detection before and during the above test.

7.16.2.5 Attempts shall be restricted to 5 min per tool (10 min for grade 4). If the test fails, it should be repeated and a further failure within 4 further attempts shall result in the overall test failing.

7.16.2.6 The results were documented as presented in Table 7.16.1.

7.16.3 Test results

Table 7.16.1 Test results

Step	Test Condition	Action	Measurement	Pass criteria	Verdict
1	The CIE should be in unset condition.	Attempt to slide a 25 x 1 x > 300 mm test blade	CIE is wired and Security Grade 2 Removal from mounting is not mandatory for Grade 2 wired CIE	The tamper signal or message shall have been generated within 11 s of the EUT exceeding the distance specified in 8.7.2.2.	N/A
2		Attempt to use pliers of thickness 5 mm and reach 150 mm		It shall not have been possible to prevent the generation of a tamper signal or message using the test blade or pliers.	N/A



Test specification:		Tamper detection - Removal from mounting test	
Test procedure:		EN 50131-3 TEST METHOD: 11.8.4 Tamper detection - Removal from mounting	
Test mode:		Compliance	
Test Date:		Verdict: N/A	
Atmospheric conditions during the test:	Temperature:	Air Pressure:	Relative Humidity:
Remarks:			

7.16.4 Results

(...) The above results comply with this section of the standard.

(...) The above results do not comply with this section of the standard.

Reference numbers of test equipment used

--	--	--

Full description is given in Appendix A.



Test specification:		Testing of I&HAS timing performance test	
Test procedure:		EN 50131-3 TEST METHOD: 11.10 Testing of I&HAS timing performance	
Test mode:		Compliance	
Test Date:		7/8/22	
Atmospheric conditions during the test:		Temperature: 25.7 °C	Air Pressure: 1001 hPa
Remarks:		Verdict: PASS Relative Humidity: 46 %	

7.17 Testing of I&HAS timing performance test procedure and results

7.17.1 Test purpose

To demonstrate the ability of the CIE to comply with 8.9 and the timing requirement of EN 50131-1:2006, 8.8.1.

7.17.2 Test procedure

7.17.2.1 Introduce a notifiable event and ensure that this takes place within the time specified by EN 50131-1:2006, 8.8.1 and 8.9.1.

7.17.2.2 With the system in set mode, trigger an intruder alarm event.

7.17.2.3 The results were documented as presented in Table 7.17.1.

7.17.3 Test results

Table 7.17.1 Test results

Step	Test Condition	Action	Measurement	Pass criteria	Verdict
1	The I&HAS should be in the set mode.	Trigger an intruder alarm event.	2 sec from the Zone 2 triggered to siren activated.	The time from triggering the event until notification takes place shall not exceed 20 s.	P

7.17.4 Results

(X) The above results comply with this section of the standard.

(...) The above results do not comply with this section of the standard.

Reference numbers of test equipment used

HL 2772	HL 3460	HL 5413
---------	---------	---------

Full description is given in Appendix A.



Test specification:		Monitoring of interconnections test	
Test procedure:		EN 50131-3 TEST METHOD: 11.11.1 Monitoring of interconnections	
Test mode:		Compliance	
Test Date:		7/8/22	
Atmospheric conditions during the test:		Temperature: 25.7 °C	Air Pressure: 1001 hPa
Remarks:		Verdict: PASS	
		Relative Humidity: 46 %	

7.18 Monitoring of interconnections test procedure and results

7.18.1 Test purpose

To demonstrate the ability of the CIE to comply with 8.8 and the timing requirement of EN 50131-1:2006, 8.8.3.

7.18.2 Test procedure

7.18.2.1 Disable the interconnection.

7.18.2.2 If the system uses non-specific interconnections, simulate another application taking permanent control of the interconnection.

7.18.2.3 The results were documented as presented in Table 7.18.1.

7.18.3 Test results

Table 7.18.1 Test results

Step	Action	Measurement	Pass criteria	Verdict
1	Disable the interconnection	<p>- CIE in "unset mode"</p> <p>-Interconnection fault was applied by removal of power wire of PIR detector from the CP</p> <p>-Limited by programmable function: Fault message was generated and displayed immediately</p>	<p>In each case, the response shall comply with the requirements of EN 50131-1:2006, 8.8.3.</p> <p>- Maximum permitted duration of unavailability: 100 seconds for Grade 2</p> <p>- Maximum permitted intervals between periodic communication signals or messages: 120 min for Grade 2</p>	P

7.18.4 Results

(X) The above results comply with this section of the standard.

(...) The above results do not comply with this section of the standard.

Reference numbers of test equipment used

HL 2772	HL 3460	HL 5413
---------	---------	---------

Full description is given in Appendix A.



Test specification:		Testing of monitoring of periodic communication test	
Test procedure:		EN 50131-3 TEST METHOD: 11.11.2 Testing of monitoring of periodic communication	
Test mode:		Compliance	
Test Date:		7/8/22	
Atmospheric conditions during the test:		Temperature: 25.7 °C	Air Pressure: 1001 hPa
Remarks:		Verdict: PASS	
		Relative Humidity: 46 %	

7.19 Testing of monitoring of periodic communication test procedure and results

7.19.1 Test purpose

To demonstrate the ability of the CIE to comply with 8.8 and the timing requirement of EN 50131-1:2006, 8.8.4.1.

7.19.2 Test procedure

7.19.2.1 The I&HAS should be in the set mode.

7.19.2.2 Apply a fault condition to the interconnect, immediately following the identified periodic communication.

7.19.2.3 The results were documented as presented in Table 7.19.1.

7.19.3 Test results

Table 7.19.1 Test results

Step	Test Condition	Action	Measurement	Pass criteria	Verdict
1	The I&HAS should be in the set mode.	Apply a fault condition to the interconnect	- CIE in "set mode" -Interconnection fault was applied by removal of power wire of PIR detector from the CP. -Limited by programmable function: Fault message was generated and displayed immediately	In each case, the response shall comply with the requirements of EN 50131-1:2006, 8.8.3. - Maximum permitted duration of unavailability: 100 seconds for Grade 2 - Maximum permitted intervals between periodic communication signals or messages: 120 min for Grade 2	P

7.19.4 Results

(X) The above results comply with this section of the standard.

(...) The above results do not comply with this section of the standard.

Reference numbers of test equipment used

HL 2772	HL 3460	HL 5413
---------	---------	---------

Full description is given in Appendix A



Test specification:		Testing of verification during setting procedure test	
Test procedure:		EN 50131-3 TEST METHOD: 11.11.3 Testing of verification during setting procedure	
Test mode:		Compliance	
Test Date:		7/8/22	
Atmospheric conditions during the test:		Temperature: 25.7 °C	Air Pressure: 1001 hPa
Remarks:		Verdict: PASS	
		Relative Humidity: 46 %	

7.20 Testing of verification during setting procedure test procedure and results

7.20.1 Test purpose

To demonstrate the ability of the CIE to comply with 8.8 and the timing requirement of EN 50131-1:2006, 8.8.4.2.

7.20.2 Test procedure

7.20.2.1 The I&HAS should be in the unset mode

7.20.2.2 Apply a fault condition to the interconnect, immediately following the identified periodic communication for the period required by Table 18, EN 50131-1 standard

7.20.2.3 Attempt to set the I&HAS

7.20.2.4 The results were documented as presented in Table 7.20.1.

7.20.3 Test results

Table 7.20.1 Test results

Step	Test Condition	Action	Measurement	Pass criteria	Verdict
1	The I&HAS should be in the unset mode	Apply a fault condition to the interconnect	Interconnection fault was applied by removal of power wire of PIR detector from the CP	-	P
2	The I&HAS should be in the unset mode	Wait period required by Table 18, EN50131-1 standard	Maximum time period from last signal or message: 20 min for Grade 2	-	P
3	The I&HAS should be in the unset mode	Attempt to set the I&HAS	- Fail to set - Setting of an I&HAS is prevented	The I&HAS shall not set	P

7.20.4 Results

(X) The above results comply with this section of the standard.

(...) The above results do not comply with this section of the standard.

Reference numbers of test equipment used

HL 2772	HL 3460	HL 5413
---------	---------	---------

Full description is given in Appendix A.



Test specification:		Event log test	
Test procedure:		EN 50131-3 TEST METHOD: 11.12 Event log	
Test mode:		Compliance	
Test Date:		7/8/22	
Atmospheric conditions during the test:		Temperature: 25.7 °C	Air Pressure: 1001 hPa
Remarks:		Verdict: PASS Relative Humidity: 46 %	

7.21 Event log test procedure and results

7.21.1 Test purpose

To demonstrate the ability of the CIE to maintain an event log and keep an accurate clock in accordance with the requirements of 8.10.

7.21.2 Test procedure

7.21.2.1 Operate the CIE to ensure correct operation of the event log, whilst ensuring the long-term accuracy of the clock.

7.21.2.2 The results were documented as presented in Table 7.21.1.

7.21.3 Test results

Table 7.21.1 Test results

Step	Test Condition	Test procedure	Measurement	Pass criteria	Verdict
1	The system initially in the unset condition.	With the CIE unset and with no alarm condition, set the time and date.	Date and time were set	-	P
2	As above	With the system unset and in the normal condition enter an authorization code at each access level.	Even log cannot be changed or deleted	There shall be no facility for a user to alter or delete the event log.	P
3	As above	If the means of recording is cyclic: Fill the event log. With the system unset, add one more mandatory event.	The minimum permitted number of mandatory events has been preserved FIFO method used	The oldest event shall be deleted by the last added mandatory events.	P
4	As above	If the CIE has the facility to record non-mandatory events, then enter the appropriate number of mandatory events as defined in EN 50131-1:2006, 8.10. Fill the remainder of the event log with non-mandatory events. Add one non mandatory event.	Mandatory events preserved 250 events (the event log capacity) Not mandatory events are not recorded	Verify that minimum permitted number of mandatory events has been preserved.	P
5	As above	Following the previous test (C), add one mandatory event.	Mandatory events logged	Verify that the new mandatory	P



Test specification:		Event log test	
Test procedure:		EN 50131-3 TEST METHOD: 11.12 Event log	
Test mode:		Compliance	
Test Date:		7/8/22	
Atmospheric conditions during the test:		Temperature: 25.7 °C	Air Pressure: 1001 hPa
Remarks:		Verdict: PASS Relative Humidity: 46 %	

				event has been logged.	
6	As above	If memory retention component(s) are non-volatile (example; EEPROM): Check data supplied by manufacturer.	Non-volatile memory in use. EEPROM may keep the data for years Non-volatile memory for >30 days	Verify that storage component(s) are non-volatile for the period required by EN 50131-1:2006, Table 21.	P
7	As above	If memory retention components are volatile (example; RAM): Remove EPS and APS from the system for the period required by EN 50131-1:2006, Table 21. At the end of this period, reapply power and check the event log.	Memory retention component is non-volatile EEPROM.	The contents of the event log shall not be lost or corrupted, except for the inclusion of event(s) caused by this test procedure (EXAMPLE: mains failure)	N/A
8	As above	In CIE with the facility to make a permanent record, follow manufacturer's instructions to make a permanent record.	Permanent record on ARC, including date and time	The events displayed on the permanent record shall accurately reflect the event log, including date and time.	P
9	As above	Checking the clock accuracy.	No deviation within 8 days with reference to NIST clock	The accuracy shall be consistent with EN 50131-1:2006, 8.10.	P
Where the I&HAS stores event logs at the ARC, the manufacturer shall provide information or means to enable this function to be tested as follows:					
10	As above	Check ability of CIE to send events to the SPT. Generate an event at the CIE.	Events stored at CIE and sent to ARC. Event are sent from SPT to ARC	Verify that the generated events are sent to the SPT.	P
11	As above	Check ability of CIE to indicate failure of transmission to the ARC: Disable the SPT and generate a number of mandatory events in accordance with EN 50131-1:2006, 8.10,	Faults of SPT indicated at CIE and ARC	Verify that a fault is indicated at the CIE (grade 1).	P



Test specification:		Event log test	
Test procedure:		EN 50131-3 TEST METHOD: 11.12 Event log	
Test mode:		Compliance	
Test Date:		7/8/22	
Atmospheric conditions during the test:		Temperature: 25.7 °C	Air Pressure: 1001 hPa
Remarks:		Verdict: PASS Relative Humidity: 46 %	

		to be reported to the ARC.			
12	As above	Enable the SPT.	Events transmitted when SPT re-enabled	For CIE grades 2, 3 and 4, the event(s) shall be transmitted when the SPT is re-enabled.	P

7.21.4 Results

- (X) The above results comply with this section of the standard.
- (...) The above results do not comply with this section of the standard.

Reference numbers of test equipment used

HL 2772	HL 3460
---------	---------

Full description is given in Appendix A.



Test specification:		Marking and documentation test	
Test procedure:		EN 50131-3 TEST METHOD: 11.13 Marking and documentation	
Test mode:		Compliance	
Test Date:		7/8/22	
Atmospheric conditions during the test:		Temperature: 25.7 °C	Air Pressure: 1001hPa
Remarks:		Verdict: PASS Relative Humidity: 46 %	

7.22 Marking and documentation test procedure and results

7.22.1 Test purpose

To check and confirm that the customer user manual and labels are in accordance with EN 50131-1 and EN 50131-3 requirements

7.22.2 Test procedure

7.22.2.1 The available last version of the user manual was read and compared with the product characteristics and standard requirements as summarized in Table 7.22.2.

7.22.2.2 The results were documented as presented in Table 7.22.1.

7.22.3 Test results

Table 7.22.1 Test results

Observation	Verdict
Labels and documentation requirements fulfilled.	Pass

Table 7.22.2 Marking and documentation requirements

EUT model: SP7000+		Documents: SP+ Series Installation Guide.PDF				
Standard/Section	Requirement	Verdict				Remark
		C	NC	NA	NT	
EN 50131-3/ 10 EN 50131-1/ 15 Marking/ Identification Labeling	Name of manufacturer	✓				See Photograph 5.1.7
	Type	✓				
	Date of manufacture batch # or serial#	✓				
	Security grade	✓				
	Environmental class	✓				
	Installation and maintenance					
	Operating temperature and humidity range	✓				
	Weights and dimensions	✓				
	Fixing details	✓				
	Installation, commissioning and maintenance instructions, including terminal identifications	✓				
	Type of interconnections	✓				
	Details of methods of setting and unsetting possible	✓				
	Where there are serviceable parts			✓		No serviceable parts
	Power supply requirement if no integrated PS			✓		Integrated PS



Test specification:		Marking and documentation test	
Test procedure:		EN 50131-3 TEST METHOD: 11.13 Marking and documentation	
Test mode:		Compliance	
Test Date:		7/8/22	
Atmospheric conditions during the test:		Temperature: 25.7 °C	Air Pressure: 1001hPa
			Relative Humidity: 46 %
Remarks:			

EN 50131-3/ 9.1.9,2 Documentation	Where PS is integrated, the information required by EN 50131-6:2008, Clause 6	✓			
	The maximum number of each type of ACE and expansion device	✓			
	The current consumption of the CIE and each type of ACE and expansion device, with and without an alarm condition	✓			
	The maximum current rating of each electrical output			✓	
	Programmable functions provided	✓			
	How indications are made inaccessible to level 1 users when level 2, 3 or 4 user is no longer accessing the information	✓			
	Masking/reduction of range signals/messages processed as "fault" or "masking" events			✓	Not mandatory for Grade 2
	Prioritization of signal and message processing and indications			✓	No Prioritization of signal and message
	The minimum number of variations of PIN codes, logical keys, biometric keys and/or mechanical keys for each user	✓			10000 for logical keys
	Method of time-limiting internal WD for level 3 access without level 2 authorization			✓	
	The number and details of disallowed PIN codes	✓			
	Details of any biometric authorization methods used			✓	No biometric
	The method used to determine the number of combinations of PIN codes, logical keys, biometric keys and/or mechanical keys	✓			Implicitly provided
	Number of invalid code entries before user interface is disabled	✓			
	Details of means for temporary authorization for user access			✓	No such temporary authorization
	If automatic setting at pre-determined times provided, details of pre-setting indication and any automatic over-ride of prevention of set	✓			
	Details of conditions provided for the set state	✓			
	Notification output signals or messages provided	✓			
	Other output configurations to interface with I&HAS components			✓	
	Criteria for automatic removal of "soak test" attribute	✓			
Number of events resulting in automatic inhibit			✓	No option to inhibit	
If ACE is Type A or Type B (see 8.7) and whether portable or moveable (see 11.14)			✓		
Component data for non-volatile memory components			✓		
Life of memory support battery			✓	No use of battery supported memory	
Optional functions provided	✓				
Additional functions provided			✓		



Test specification:		Marking and documentation test	
Test procedure:		EN 50131-3 TEST METHOD: 11.13 Marking and documentation	
Test mode:		Compliance	
Test Date:		7/8/22	
Atmospheric conditions during the test:		Temperature: 25.7 °C	Air Pressure: 1001hPa
		Relative Humidity: 46 %	
Remarks:			

	Access levels required to access such additional functions provided			✓	
	Details of any programmable facility that would render an I&HAS non-compliant with EN 50131-1:2006, 8.3.13 or compliant at a lower security grade, with instruction on consequent removal of compliance labelling			✓	
Operating instructions					
	operating instructions for all security and non-security functions available to the user	✓			
	standard(s) to which compliance is claimed for product	✓			
	security grade to which the CIE and ACE comply	✓			
	environmental class	✓			
	the minimum number of variations of logical and/or mechanical keys for each user	✓			
	the number and details of disallowed codes	✓			
	user programmable functions provided	✓			
	where there are user serviceable parts (EXAMPLE: fuses), their type and value			✓	No serviceable parts
EN 50131-1/ 14.2 Documentation	Name of manufacturer	✓			
	Description of equipment	✓			
	Clear and concise documentation	✓			
	Standard to which component claims compliance	✓			
	Name or mark of the certification body	✓			
	Security grade	✓			
	Environmental class	✓			

7.22.4 Results

- (X) The above results comply with this section of the standard.
- (...) The above results do not comply with this section of the standard.

Reference numbers of test equipment used

HL 2772	HL 3460
---------	---------

Full description is given in Appendix A.

**8 APPENDIX A Test equipment and ancillaries used for tests**

HL No	Description	Manufacturer	Model	Ser. No.	Due Cal./Check
2772	HygroThermometer, Min/Max Memory	Delta TRAK	13301	NA	14-Dec-22
3460	Precision Barometer, 870 - 1050 hPa	LUFFT Mess- und Regeltechnik GmbH	DKD-K-26701	100469	17-Jul-24
3477	Test rod 2.5 mm / 100 mm, IP3X per IEC 60529	Hermon Laboratories	IP3	3477	13-Oct-24
4548	Tamper test tool set. EN50131-3:2009 STD	Hermon Laboratories	TTT-1	NA	25-Nov-22
5413	Digital Stopwatch	Shenzhen Huibo Industrial & Trading Co. Ltd.	PC396	NA	15-Aug-23
3013	ED&D Universal Spring Hammer	Educated Design & development, Inc.	F 22.50	I1145127	30-Apr-23



9 APPENDIX B Test laboratory description

Testing laboratory and location	<p>Tests were performed at Hermon Laboratories, which is a fully independent, private safety, EMC, telecommunication and environmental testing facility. Hermon Laboratories is accredited by American Association for Laboratory Accreditation (A2LA, USA) according to ISO GUIDE 17025 (certificate No. 839.01) and accredited as NCB.</p> <p>The safety/Security laboratory has gained numerous certifications and accreditations from National Certification Bodies including UL, ETL, TUV, MET, SII, Telefication and others, and provides solution for global safety certification in various product categories.</p> <p>Address: P.O. Box 23, Binyamina 30500, Israel. Telephone: +972 4628 8001 Fax: +972 4628 8277 e-mail: mail@hermonlabs.com website: www.hermonlabs.com</p> <p>Person for contact: Michael Brun, Product Safety Group Manager.</p>
--	--

10 APPENDIX C Abbreviations and acronyms

ARC	alarm receiving centre
ACE	ancillary control equipment
BBA	broad band adapter
°C	degree Celsius
C	compliant
CP	control panel
CIE	control and indicating equipment
EUT	equipment under test
HL	Hermon Laboratories
hPa	hectopascal
kg	kilogram
m	meter
min	minute
mm	millimeter
NA	not applicable
NT	not tested
NC	not compliant
gr.	Gram
RFT	Reduced functional test
sec	second
WD	warning device
CP	Control Panel
DP	dual path



11 APPENDIX D Tests specifications

- | | | |
|----|---|---|
| 1. | EN 50131-1:2006+A1:2009+A2:2017
+A3:2020 | Alarm systems- Intrusion and hold-up systems
Part 1: System requirements |
| 2. | EN 50131-3:2009 | Alarm systems-Intrusion and hold-up systems
Part 3: Control and indicating equipment |

12 APPENDIX E Measurement uncertainties

Parameter	Uncertainty estimation at 95% confidence	
	Calculated	Limit
Air pressure	± 0.8 mBar	± 4.1 mBar
Temperature	± 1.3°C	± 2°C
Humidity	± 2.86 %	± 5.0 %
Time measurement using the oscilloscope cursor	± 1.2%	± 10%
Time measurement using stopper watch (20 s intervals)	± 1.7 %	± 10 %
Impact energy measurement	± 6.1%	± 10%

Note: Pass/Fail decision was based on nominal values

End of Test Report