



Mounting to a Flat Surface



Vertical Mounting to DIN35

- ❖ Digital Modulation
- ❖ 1x SC/PC Optical Port
- ❖ 2x Data BUS
- ❖ 1x Relay LOCK NO/NC
- ❖ Overvoltage Protection
- ❖ Current Limiter in Supply
- ❖ Working Temperature from -40°C to +70°C
- ❖ Operating Range of Components -40°C to +85°C

PRODUCT NAME	CODE	SUPPLY
FIWRE-S-PDS	1-004-290	10-20VDC ⁽¹⁾
TDW-S-PDS-BOX/12	1-504-290	10-20VDC ⁽¹⁾
RDW-S-PDS-BOX/12	1-604-290	10-20VDC ⁽¹⁾
Holder for Mounting to DIN35 and Flat Surface is Included.		
⁽¹⁾ Bus Power Supply		

Connection to the M-BUS of ABI System

compatibility



Connection to the BUS2 of MB SECURE System

compatibility

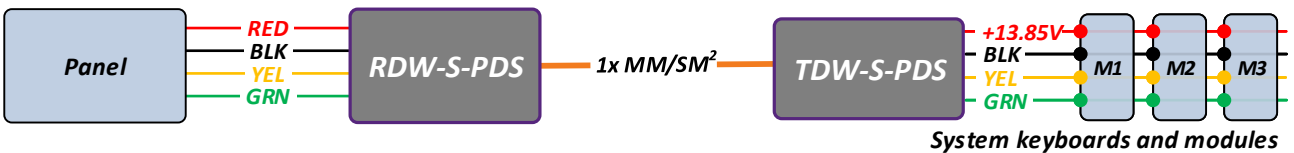

Connection to the BUS of PARADOX EVO System

compatibility



Connection to the bus of SATEL INTEGRA System

compatibility

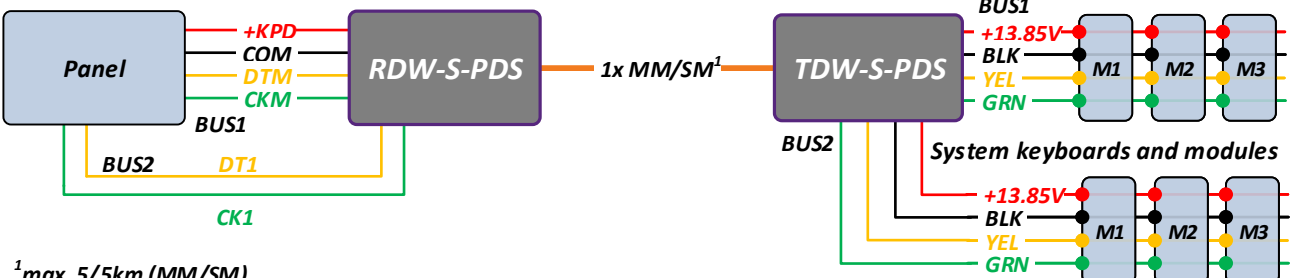

¹max. 5/5km (MM/SM)

²max. 5/10km (MM/SM)

Description and Technical Parameters

compatibility

These fibre optic converters are designed for the transmission of system buses of the control panels. ABI PKE, MB SECURE HONEYWELL, PARADOX EVO a SATEL INTEGRA.

	Parameter	Value	Unit	Note
BUS	Overvoltage Protections	600	W	Pulse 10/1000 μ s
Optics	Output Optical Power	-14 to -8 / -10 to 0	dBm	SM / MM
	Sensitivity	-31	dBm	SM / MM
	Optical Fibres	1x SM 9/125 - SC connectors	μ m	Grinding PC
		1x MM 50(62.5)/125 - SC conn.	μ m	Grinding PC
Optical Range	ABI	5/10	km	SM / MM
	MB SECURE	5/10	km	SM / MM
	PARADOX EVO	5/5	km	SM / MM
	SATEL INTEGRA	5/5	km	SM / MM
ATTENTION: The Converters Contain Class 1 Laser Sources According to EN 60825-1-1				
LOCK Relay	RDW-S-PDS	NO/NC Contact with max. 125VAC/0.5A or 60VDC/0.3A		
		NO Contact Closed = Communication OK		
Power Supply	Voltage	10-20	VDC	From Bus
	Current at 12VDC	Max. 100	mA	
	Protections	Overvoltage / Current	600W-Pulse 10/1000 μ s / Reversible	
Environment	Operational Tange	-40..+70	$^{\circ}$ C	Temperature of Environment
	Humidity	Max. 95	%	Non-condensing
Mechanical	Dimensions - w / h / l	110 x 97 x 30 (37)	mm	With the DIN Holder
Parameters	Weight	typ: 0.2	kg	
The producer retains the right to change any technical parameters without previous written or published notification.				

Recommended Topology

compatibility

When designing a topology, we recommend keeping to the topology of the bus and not making more than a 1 meter branch from the bus. Any longer turns can result in communication reflections and increased susceptibility to interference. In the diagram below are suggested additional restrictions on the transfer of the optical fiber and the use of multiple optical converters..

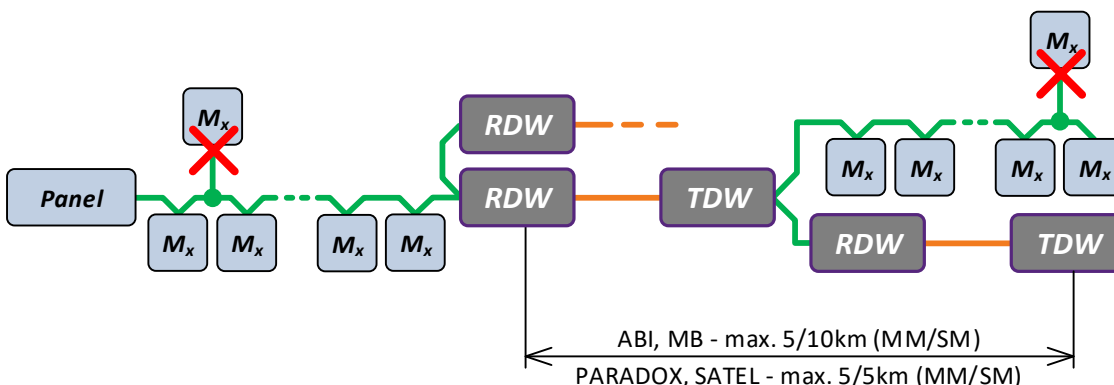

Other restrictions on optical transmission

Maximum number of RDW + TDW pairs connected in series = 3

Maximum number of RDW + TDW pairs connected in parallel = 3

Dimension

universality

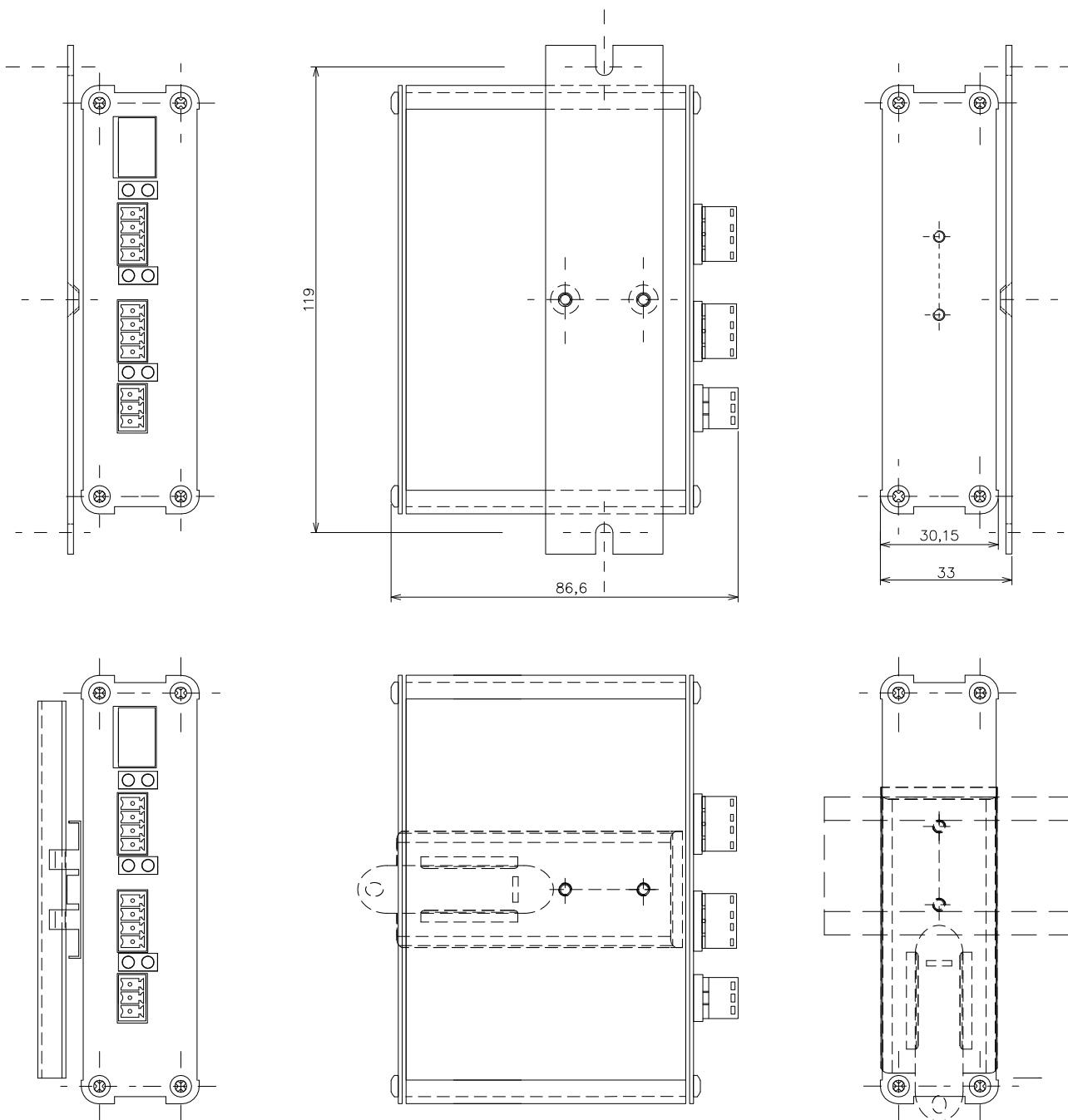

REVISION: 201602 – Pre-production Version
201603 – Production Version
202001 – Supporting ABI, MB-SECURE

Connection to the M-BUS of ABI System

compatibility

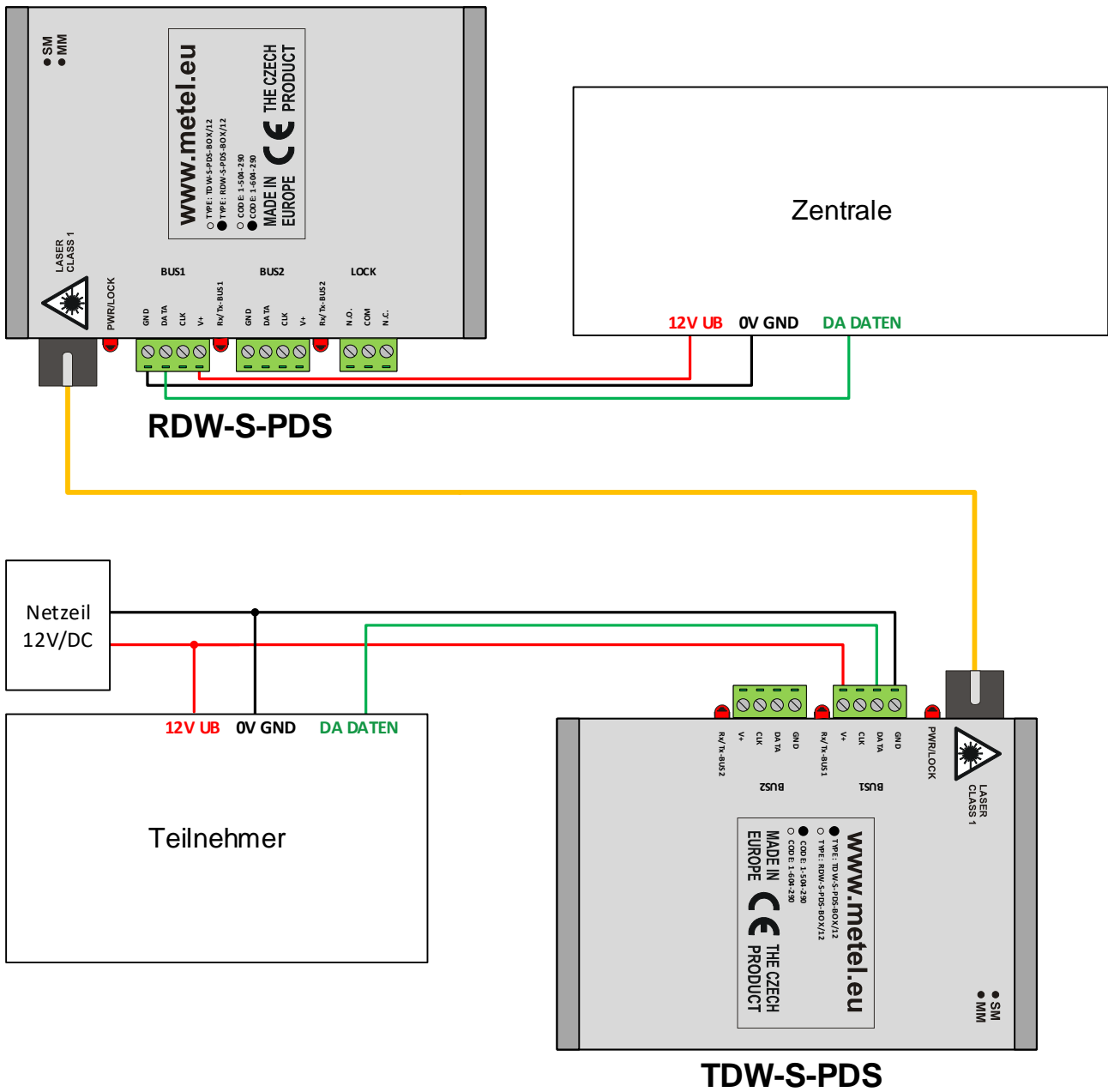

Connection to the BUS2 of MB SECURE System

compatibility

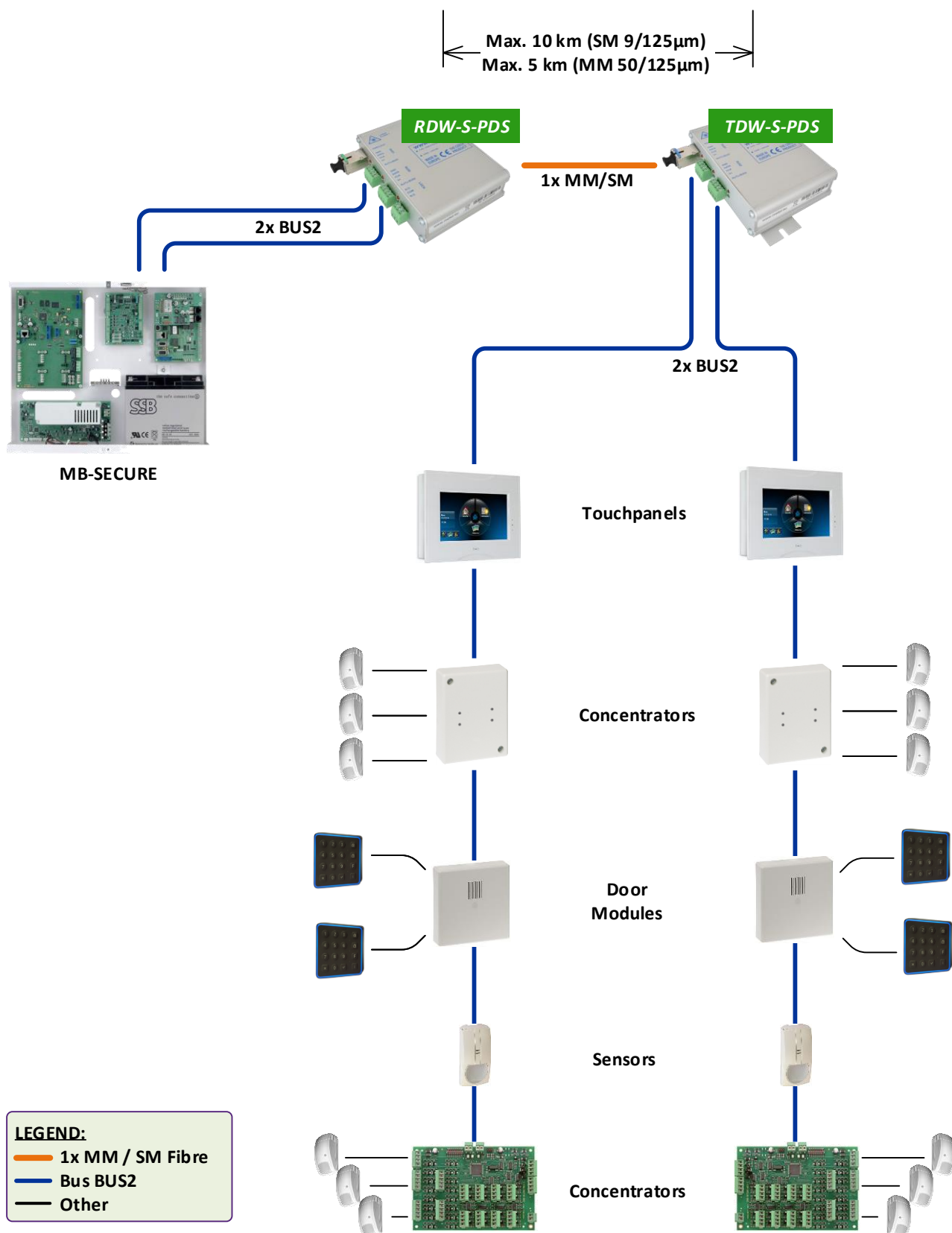

Connection to the BUS of PARADOX EVO System

compatibility

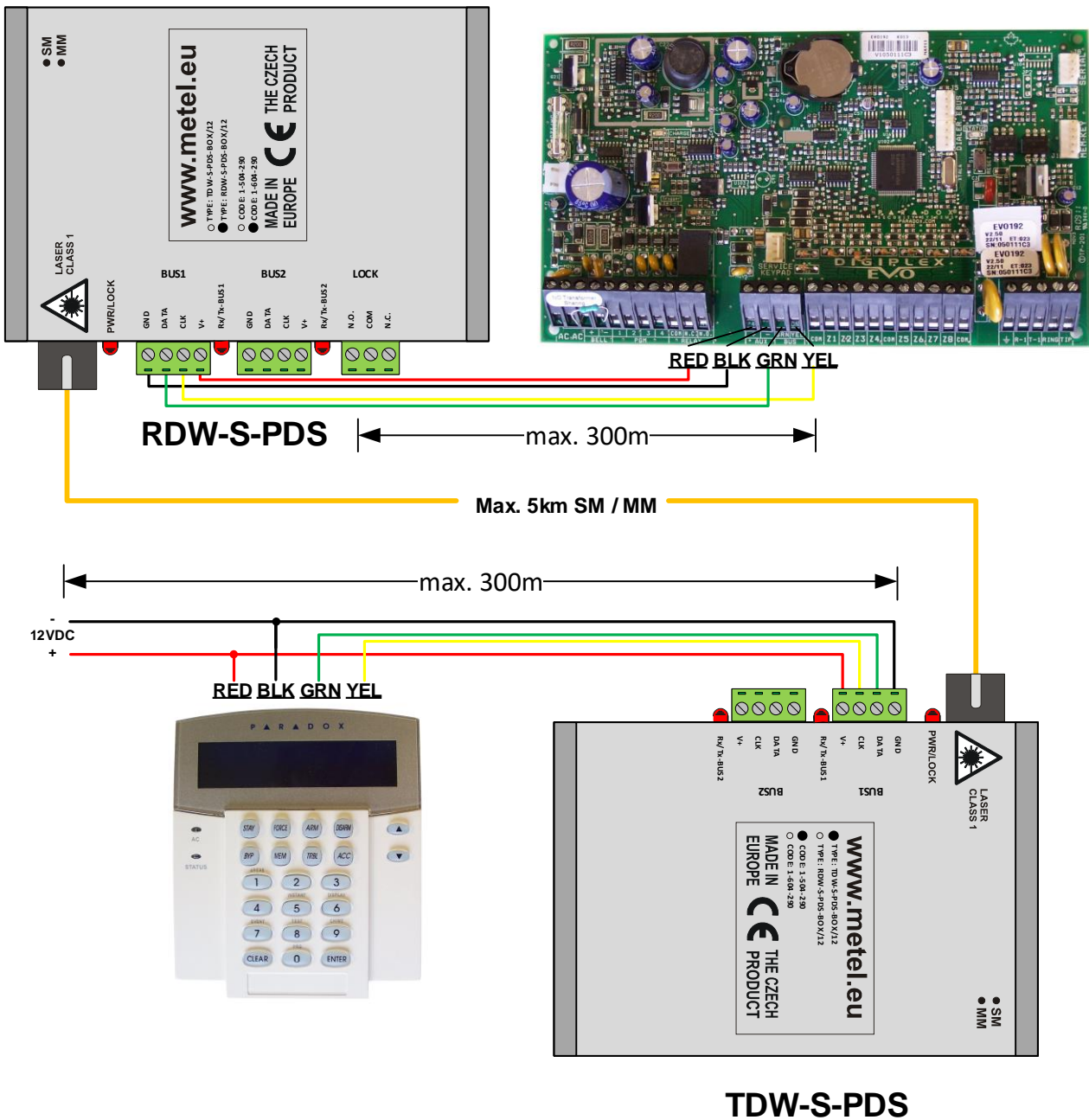

Connection to the bus of SATEL INTEGRA System

compatibility

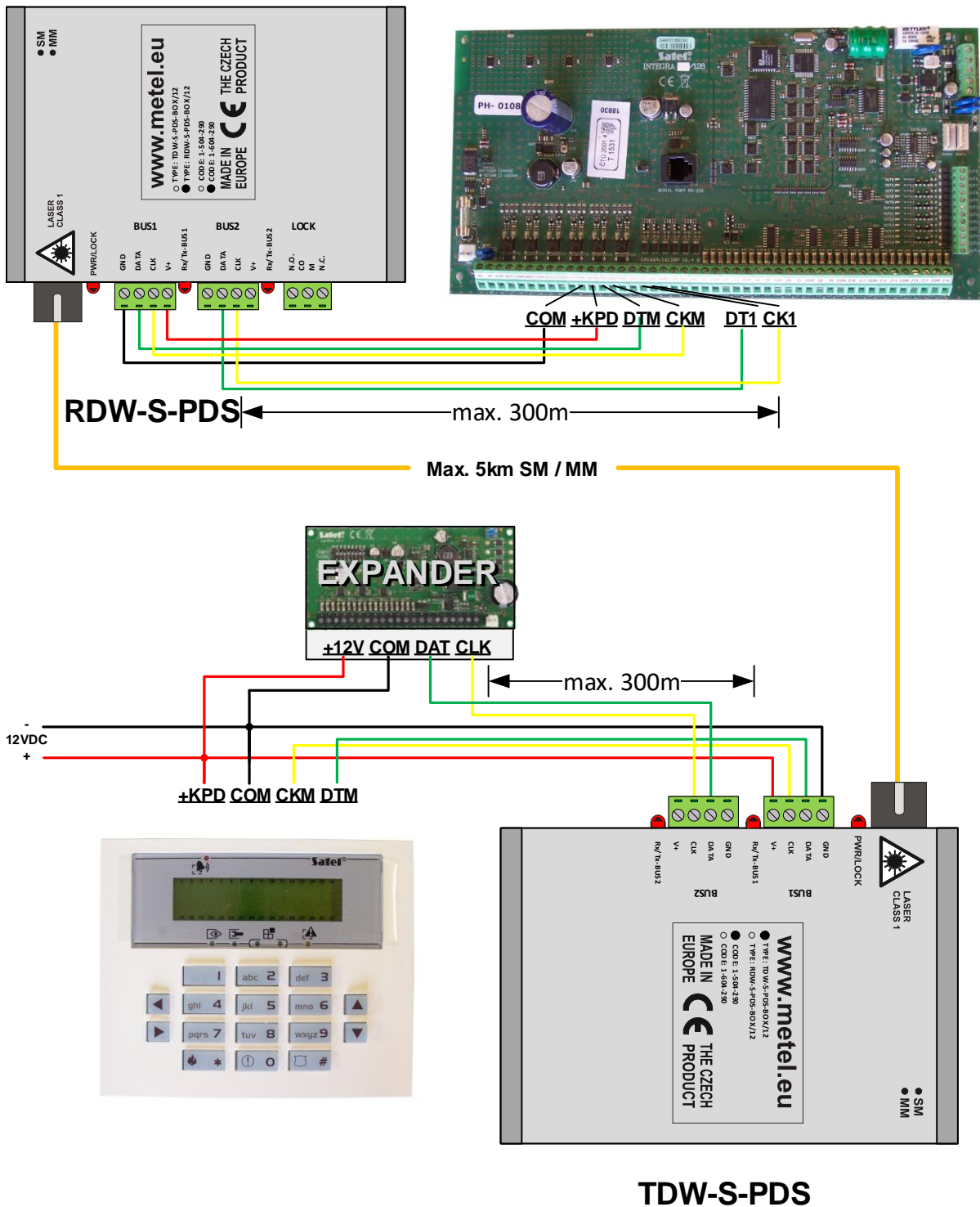

FIWRE-S-PDS

Optoconverters ABI, MB SECURE, PARADOX EVO, SATEL INTEGRA Buses

1. Mounting

Place the RDW-S-PDS to the side of the alarm system.
Place the TDW-S-PDS to the side of the modules (keyboards, modules...).

Mount the converters to either a flat surface or the DIN35 rail.

2. Connect Supply

12VDC from bus on the panel side and from the DC source on the module side between V + and GND terminals, the power supply connection is signaled by the yellow POWER LED.

ⓘ The converters include overvoltage protections on data ports and power supply providing sufficient protection of the converters against overvoltage in the LPZ1 and LPZ2 zones. In the case of installation of transmitters in an outdoor environment (zones LPZ0A and LPZ0B), we recommend placing them in switchboards providing electromagnetic shielding. Further information on this issue can be found at www.metel.eu in the document "Surge protection of IP CCTV system according to EN 62305".

3. Connect Optic Fiber

Terminated by a SC connector (grinding PC). After interconnection of the TDW-S-PDS and the RDW-S-PDS LED LOCK switches off. The max. length of the optical fiber is:

- MM/SM - 5/5 km for systems PARADOX EVO and SATEL INTEGRA,
- MM/SM – 5/10km for systems ABI and MB SECURE.

ⓘ The optical path used must meet the minimum technical requirements specified on www.metel.eu in the document "xDW - minimum requirements for the quality of the optical path". Failure to comply with these requirements may result in a significant reduction in the quality of communication.

4. Connect Signal Wires

Proceed according to the type of alarm system with the pictures on the previous pages.
Connect the data lines from the alarm system to TDW-S-PDS to terminals DATA and CLK.

5. Indications

LED PWR - by switching on detects supply
LED LOCK - by switching on detects relay closure
- by switching on detects optics interruption
- by switching on detects failure of a remote device

LED Rx/Tx1 - data line
- red LED Tx blinking – data transmission
- green LED Rx blinking – data reception

LED Rx/Tx2 - data line
- red LED Tx blinking – data transmission
- green LED Rx blinking – data reception

ⓘ The conversion of data from the metallic line to the optics and back is completely transparent. The converters do not contain any firmware that would process the data in any way. Therefore, the converters do not require any special configuration. Their installation and commissioning are very simple and fast.

