

### Features of the power supply:

- power output 1A/7,5VDC\*
- universal AC voltage range 90÷264V
- high efficiency 77%
- standby power <0,3W
- efficiency level: V
- IP 67 enclosure
- construction enables to assembly in installation box
- protections:
  - short-circuit protection SCP
  - surge protection (AC input)
  - overload protection OLP
- warranty – 2 year from the production date

## 1. Technical description.

### 1.1. General description.

The PSU is intended for 230VAC mains supply to devices that require stabilised voltage of **7,5V DC**. The unit is protected against a short circuit and an overload and a surge.

### 1.2. Technical parameters.

Supply voltage	90 ÷ 264V AC 50+60Hz
Current consumption	0,115A@230V AC max.
Supply power	7,5W max.
Efficiency	77%
Output voltage	7,5VDC
<b>Output current <math>t_{AMB}&lt;30^{\circ}C</math></b>	<b>1A instantaneous current - refer to graph 1.</b>
<b>Output current <math>t_{AMB}=40^{\circ}C</math></b>	<b>0,7A - refer to graph 1.</b>
Ripple voltage	100mV p-p max.
Short-circuit protection SCP	electronic, automatic recovery
Overload protection OLP	105-150% of power supply, automatic recovery
IP protection class	IP67
Operation conditions	temperature 0 °C+40 °C relative humidity 20%...90%
Dimensions (LxWxH)	50 x 48 x 25 [mm]
Net/gross weight	0,10kg / 0125kg
Protection class PN-EN 60950-1:2007	II (second)
Lenght of DC cable	0,5 m
Lenght of AC cable	0,3 m
Storage temperature	-20°C...+60°C

\* In order to extend the life of the power supply, the load current of 0,7A is recommended.

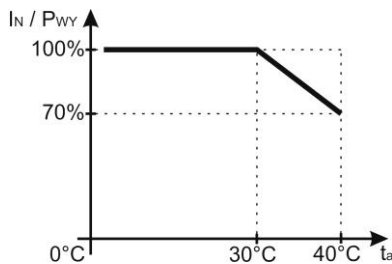

Graph 1.  
Relation between output current and ambient temperature (instantaneous load).

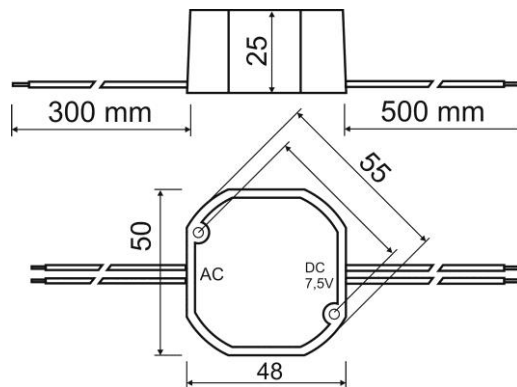

Fig.1. Mechanical view and dimensions of the PSU.

\* Refer to graph 1

### 1.3. Accessories.

Available accessories for the power supplies are: fuse blocks and cable adapters. For details –visit [www.pulsar.pl](http://www.pulsar.pl).

## 2. Installation.

### 2.1. Requirements.

The PSU is to be mounted by a qualified installer, holding relevant permits and licenses (applicable and required for a given country) for 230V/AC interference and low-voltage installations. The unit should be mounted in confined spaces, in accordance with the 2nd environmental class, with normal relative humidity (RH=90% maximum, without condensation) and temperature from 0°C to +40°C. The device should be installed in the metallic enclosure (cabinet, intended device). In order to meet the LVD and EMC requirements, the rules concerning: supply, development and shielding ought to be followed - accordingly to the application.

### 2.2. Installation procedure.

1. Fit the power supply inside the box or other device.
2. Connect the DC cables to the load or to the terminal block.
3. Connect the 230V AC leads to the 230V power strip.
4. Once the tests and operation control have been completed, the enclosure/cabinet can be locked and the 230V AC power switched on.

## 3. Maintenance.

Any and all maintenance operations may be performed following the disconnection of the power supply from the power network. The power supply does not require any specific maintenance procedures, however, in the case of significant level of dust, it should be cleaned with compressed air.



### WEEE MARK

**According to the EU WEE Directive – It is required not to dispose of electric or electronic waste as unsorted municipal waste and to collect such WEEE separately.**

---

### Pulsar

Siedlec 150, 32-744 Łapczyca, Poland  
Tel. (+48) 14-610-19-40, Fax. (+48) 14-610-19-50  
e-mail: [biuro@pulsar.pl](mailto:biuro@pulsar.pl), [sales@pulsar.pl](mailto:sales@pulsar.pl)  
http:// [www.pulsar.pl](http://www.pulsar.pl), [www.zasilacze.pl](http://www.zasilacze.pl)