

# SIGNALINE HEAT

## Signaline

### FT-EOL-EN



## Installation Manual



Tel: +44(0)1252 725257

Revision 2 (2023)

© 2023/24 LGM Products Ltd.

Email: [sales@lgmproducts.com](mailto:sales@lgmproducts.com)

Web: [www.signaline.com](http://www.signaline.com)

ISO 9001:2015 certified

Address: LGM Products Ltd, Unit 3 Quantum Business Park, Beacon Hill Road, Hampshire, GU52 8EA

United Kingdom



# Contents

**Key Points**

**Product Overview & Features**

**Typical System Configuration**

**Alarm and Fault Tests**

**Mounting the FT-EOL-EN**

*Please read this instruction leaflet thoroughly before commencing installation.*



## Key Points

- ⇒ Install the Signaline end of line unit (FT-EOL-EN) accordingly to meet local and country installation requirements.
- ⇒ The FT-EOL-EN must be installed in accordance with BS 5839-1:2017 (or country equivalent) and IEC 60364 and Authorities Having Jurisdiction.
- ⇒ Ensure the product is installed, commissioned and maintained by qualified professionals according to good engineering practices and who have received sufficient training on the unit.
- ⇒ Only use Signaline FT-EN linear heat detection cable with the Signaline FT-EOL-EN.
- ⇒ Test the Signaline FT-EN linear heat detection cable before and after installation but before connecting it to the Signaline FT-EOL-EN using a multi-meter.
- ⇒ Ensure the maximum ambient temperature rating of the Signaline FT-EOL-EN will not be exceeded during storage or normal operating conditions.
- ⇒ Ensure any cable glands used are tightened to form a secure and moisture proof seal around the Signaline FT-EN linear heat detection cable.
- ⇒ **Do not paint the Signaline FT-EOL-EN**
- ⇒ **Do not connect lengths of Signaline FT-EN linear heat detection cable in 'T' connections or spurs.**
- ⇒ **Do not place the Signaline FT-EN linear heat detection cable under excessive tension or crush the cable by over-tightening of the cable glands**



## Product Overview

The Signaline FT-EOL-EN has been approved to EN54-28:2016 for use with the Signaline LocatorPlus-EN and Signaline FT-EN Linear Heat Detection cables.

It is designed to effectively terminate up to two zones of Signaline FT-EN Linear Heat Detection cables in a secure and weatherproof enclosure.

Furthermore, the built in switches for testing a fault and alarm condition allow the integrity of the whole system to be functionally checked in situ, providing comprehensive testing and maintenance of the system.

With the ability to terminate up-to two zones of Signaline FT-EN Linear Heat Detection cable, the Signaline FT-EOL-EN is ideally suited for use with the Signaline LocatorPlus-EN, especially when used in interlocking mode to prevent false alarms. In this mode, two Signaline FT-EN linear heat detection cables are run side-by-side and an alarm is only activated on the fire alarm control panel when both cables trigger. In this situation the Signaline FT-EOL-EN provides a cost and space saving over separate termination enclosures.

### Product Features

- EN54-28:2016 Approved for use with the Signaline LocatorPlus-EN control unit and Signaline FT-EN Linear Heat Detection cables
- Provides a simple and straightforward method to carry out a functional test on the system
- Quickly simulate a fault condition
- Quickly simulate an alarm condition
- Secure and weatherproof enclosure
- Supplied with 2x IP67 rated cable glands
- Secure weatherproof enclosure

<b>Model</b>	Signaline FT-EOL-EN
<b>Dimensions</b>	94 x 94 x 57mm
<b>IP Rating</b>	IP66 (supplied with 2x IP67 rated glands)
<b>Operating temp.</b>	-35°C to +55°C
<b>Terminal blocks</b>	EOL: 2x 5mm Rising Clamp Cable: 2x removable header 5mm Rising clamp
<b>Environmental Group</b>	III
<b>Approval</b>	EN54-28:2016 (UL-EU-01128-CPR)



### Typical System Configuration

The Signaline FT-EOL-EN, is intended to be installed at the end of a zone of Signaline FT-EN linear heat detection cable (see Fig 1).

Two end-of-line resistors, one for each zone, are provided with the Signaline FT-EOL-EN. These should be securely screwed into the end-of-line resistor terminals on the Signaline FT-EOL-EN (see Fig 2.).

The Signaline FT-EN linear heat detection cable should be screwed into the Zone 1 or Zone 2 terminals, as required, and the cable gland tightened (avoid excessive tightening) around the cable to create a secure, waterproof connection.

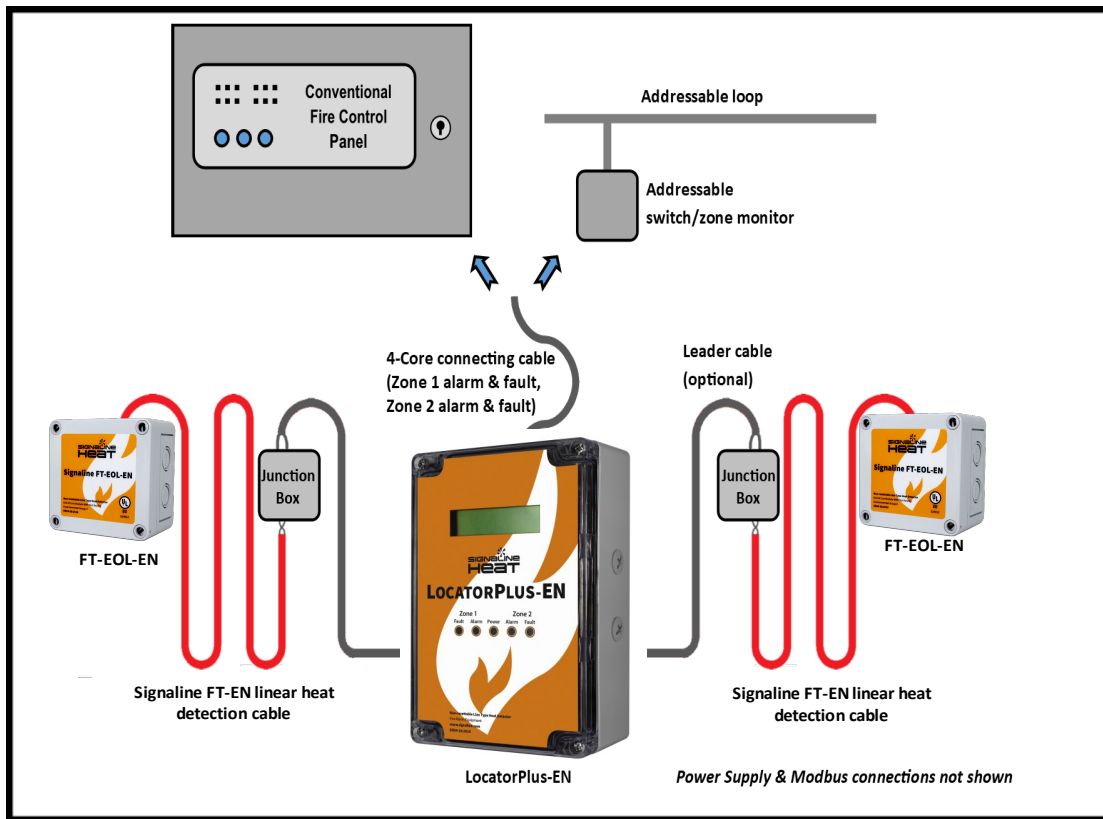

Fig 1. Typical wiring configuration for Signaline FT-EN linear heat detection cable, FT-EOL-EN and the LocatorPlus-EN



### Alarm and Fault Tests

To simulate an alarm, press and hold the push switch (see Fig 2) for the corresponding zone until the Signaline LocatorPlus-EN (and fire alarm control panel) triggers an alarm.

To simulate a fault condition, toggle the test fault switch down (see Fig 2). The Signaline LocatorPlus-EN (and fire alarm control panel) should register a fault condition.

Return the toggle switch to the normal position to clear the fault.

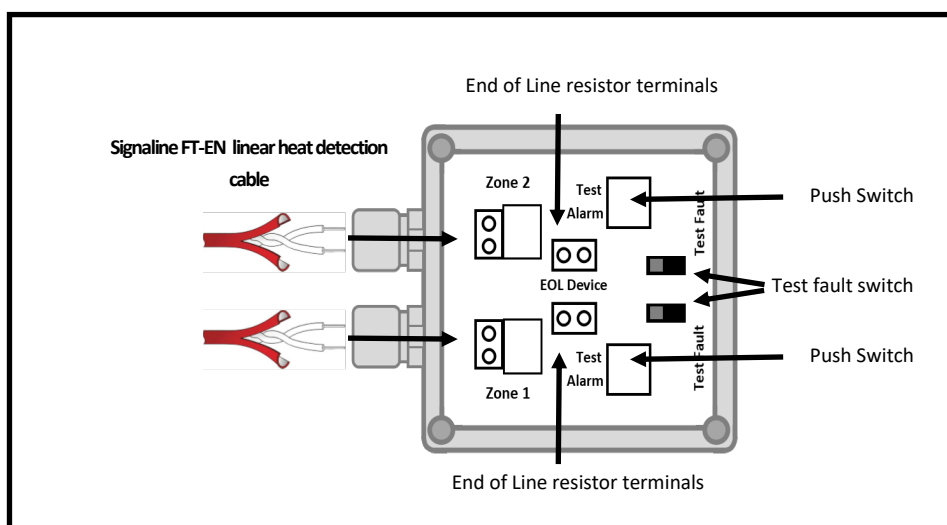

Fig 2. Connection diagram for Signaline FT-EOL-EN



### Mounting the FT-EOL-EN

The Signaline FT-EOL-EN is intended to be wall mounted. 4 holes should be drilled according to the mounting dimensions below. The corresponding mounting holes on the FT-EOL-EN are found by removing the lid and are located in the same place where the lid screws fix into the base.

Suitable screws for the type of wall the Signaline FT-EOL-EN is to be mounted on will need to be provided for separately. The minimum head diameter is 5.5mm and the maximum head diameter is 8mm. The maximum screw thread diameter is 5mm.

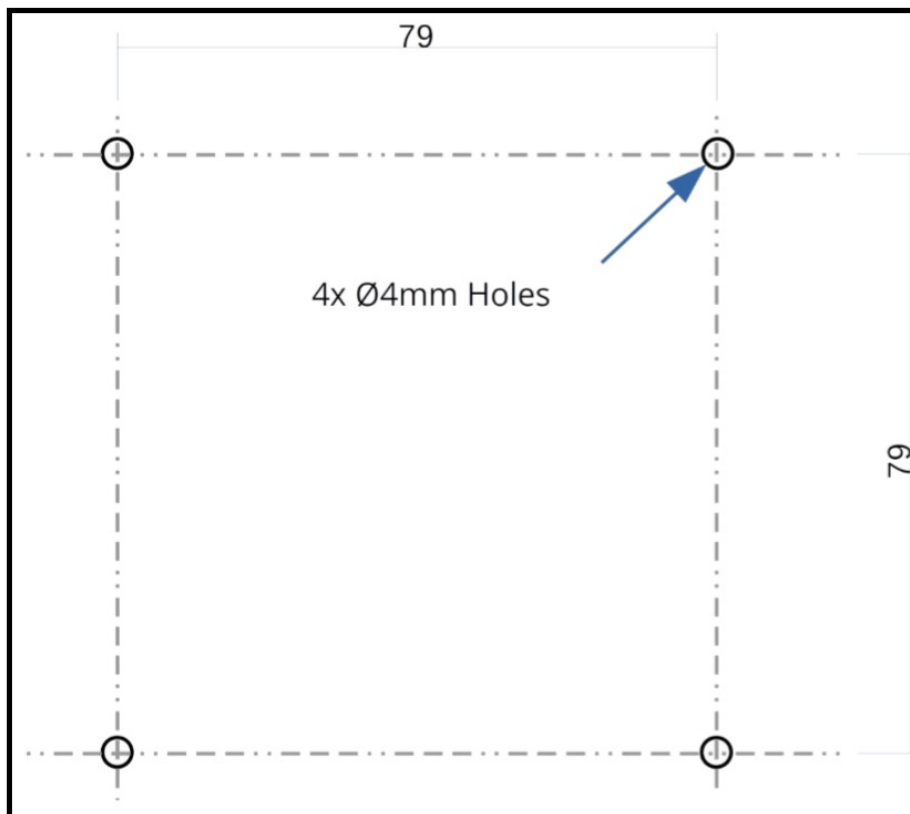

Fig 3. FT-EOL-EN mounting specs

The Signaline FT-EOL-EN is part of the Signaline family of products.

To see our full range please visit [www.signaline.com](http://www.signaline.com)



**For product support, contact us at [technical@lgmproducts.com](mailto:technical@lgmproducts.com)**

**Or call 01252 725257 to speak to our sales team**

Tel: +44(0)1252 725257

Revision 2 (2023)

© 2023/24 LGM Products Ltd.

Email: [sales@lgmproducts.com](mailto:sales@lgmproducts.com)

Web: [www.signaline.com](http://www.signaline.com)

ISO 9001:2015 certified

Address: LGM Products Ltd, Unit 3 Quantum Business Park, Beacon Hill Road, Hampshire, GU52 8EA

United Kingdom